

Power Transmission



Experiment Objectives

Comprehensive and practical knowledge of high-voltage power transmission lines using a 3-phase line model to measure the characteristic parameters of a power transmission line, its quantitative operational characteristics, and qualitative terms. These characteristic parameters include active and reactive resistance (inductive and capacitive), star and delta voltages, voltage differences, line, load and charging currents, short-circuit current in the event of a short circuit, active and reactive power (capacitive and inductive), power dissipation and inherent reactive power.

- Characteristic line parameters.
 - Transmission line operation under following conditions:
 - a) no-load,
 - b) matching,
 - c) symmetric short circuit,
 - d) asymmetric short circuit,
 - e) different types of load (resistive, inductive),
 - f) asymmetric operation.
 - Transmission losses and efficiency.
 - Reactive power compensation (parallel and series mode).
 - Earth fault compensation.
 - Neutral-point connection method.
 - Voltage range of a three-phase, variable transformer in an economy circuit.
 - No-load and short-circuit behavior of an autotransformer.
 - Combination of a three-phase, variable transformer with a line model and connected load.
 - Automatic voltage adjustment at any load current.
 - Step-up and step-down transformer.
-

Equipment

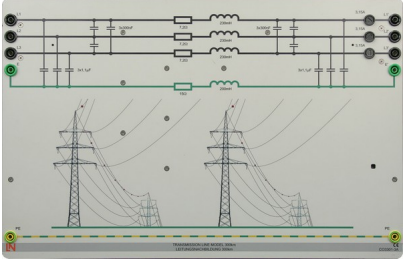
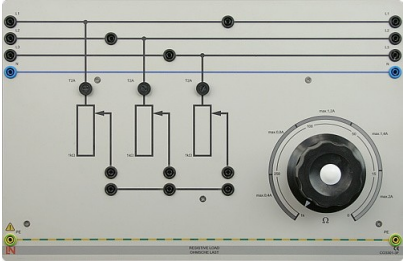
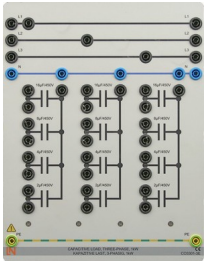
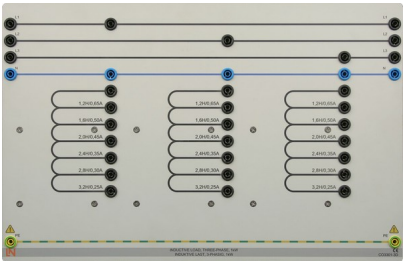
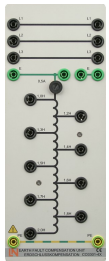
Equipment	Description	Part Number
	<p>Transmission line Model 150 km/300 km (93.2 miles/186.4 miles)</p>	<p>CO3301-3A</p>
	<p>Resistive load</p>	<p>CO3301-3F</p>
	<p>Capacitive load (3-phase, 1 kW)</p>	<p>CO3301-3E</p>
	<p>Inductive load (3-phase, 1 kW)</p>	<p>CO3301-3D</p>
	<p>Earth fault compensation unit</p>	<p>CO3301-4X</p>



Adjustable three-phase supply (0 - 400 V / 2 A, 72 PU)

CO3301-3Z7
ST8008-4S
[Manual](#)

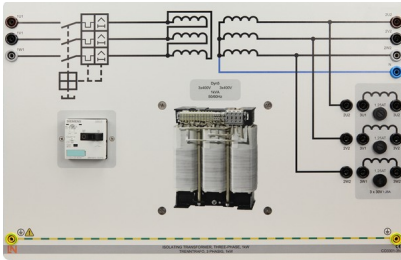

Isolating transformer, Three-phase, 1 kW

CO3301-3N

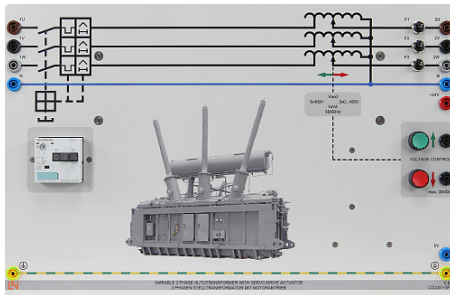

Three-phase variable transformer with motor drive

CO3301-3P
[Manual](#)

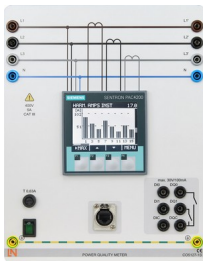

Power Quality Meter

CO5127-1S
[Manual](#)



Analog/digital multimeter, power meter/
power-factor meter, software

CO5127-1Z8
[Manual](#)

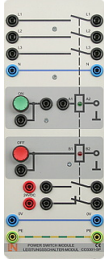

Power switch module

CO3301-5P
Manual

The experiments use a 380-kV overhead transmission line model. In the steady state, this model has all the electrical properties of a real overhead line operating at this voltage level; a simple switchover mechanism permits lengths of 150 km and 300 km (93.2 mi and 186.4 mi) respectively to be realized without a need for changing the experimental setup. This not only makes it possible to investigate a line's operating behavior in the normal state (i.e. mixed resistive-inductive load), but also in the three important, special cases comprising no-load, matching and short circuit at the transmission distances typically involved. The line model has three phases and an additional return conductor enabling an investigation of asymmetric faults. The model can also be used to realize various types of neutral point wiring, besides examining responses to earth faults and earth short circuits.

The experiments are particularly realistic, thanks to their voltage and current scales of 1:1000 respectively; consequently, 1 V in the model corresponds to 1 kV on a real line, while 1 A corresponds to 1 kA. The same ratio applies to the powers: 1 W (or VA) in the model corresponds to 1 MW (or 1 MVA) on a real line. As a result, the measurement results obtained during the experiments can be applied very easily to real systems. The identical scales for the voltage and current also permit the line impedances of a real transmission system to be applied in the same fashion to the line model.

The employed models represent a 300-km long (186.4 mi), 380-kV overhead transmission line with the constants R' , X' , C' . Due to the line-to-line voltages of 380 V, 220 V and 110 V employed in the experiments (i.e. 380 kV / 220 kV / 110 kV in the case of a real line), a transmission line possessing the same constants remains realistic.

To ensure efficient energy transmission, an overhead line's length is restricted in accordance with the specified voltage levels. As a rule of thumb: "Maximum line length in relation to voltage level = 1 km / 1 kV". Accordingly, a 380-kV overhead line's length should be limited to 380 km (186.4 mi).

Background/Introduction

Power is generated only in areas near load clusters. For this reason, supply networks designed to transmit high powers must be able to operate at variable voltage levels. For technical and financial reasons, in particular, networks operating at high and extra-high voltages usually consist of overhead transmission lines. Only a combination of individual sub-networks into an integrated power grid makes it possible to operate large power station units at high efficiencies. Moreover, only integrated operation makes it possible to maintain a practical reserve to allow for potential failure. In view of these advantages of integrated power grids, practically all networks in The Americas operate continuously in parallel mode at a standard frequency of 60 Hz (or 50 Hz in western European nations).

The higher the power to be transmitted and the greater the distance between the power source and consumer, the higher the *transmission voltage*. As this voltage increases, naturally so does the required height of the pylons in order to ensure that certain safety clearances are maintained. When speaking of electricity supply, a distinction is made between extra-high voltage networks (220 - 380 kV and beyond), high-voltage networks (60 - 110 kV), medium-voltage networks (10 – 30 kV) and low-voltage networks (in which power transmission typically takes place at a voltage of 600 V). This classification has been performed arbitrarily in accordance with the electricity industry's specifications. In contrast, regulations laid down by VDE (Association of German Electrical Engineers) only distinguish between low voltage (up to 1000 V) and high voltage (over 1000 V).

During actual operation, it is naturally not possible to constantly maintain the voltages at all of a network's nodes at their nominal values. At least the voltage bandwidth in networks employing high and extra-high voltages fluctuates between roughly $\pm 10\%$ of the nominal voltage. Control transformers between the various network levels ensure that customers in spite of that receive voltages close to the respective nominal values.

The conductor cross-section should be selected so as to minimize the voltage losses along the routes to the consumers, while also preventing impermissible high current densities which might overheat the conductive materials. The outcome is economical cross-sections standardized not only for the sake of mutual compliance but also to ensure compatibility with the respective voltages mentioned earlier.

In the energy industry, the three phases of a three-phase system make up what is known as the electric circuit. To economize on line routing, the pylons are often occupied by several (up to six) electric circuits.

The voltage present between any two outer conductors (phases) of a three-phase system is agreed as representing the nominal voltage or rated voltage. The permissible values of the continuous current (associated with heating) and voltage (associated with the air's breakdown resistance) determine the maximum power which can be transmitted along a line; this is also known as the thermal power limit. It is not to be confused with the natural power transmitted if the line is terminated by a resistive load of the same magnitude as the characteristic impedance.

Three-phase Overhead Power Transmission Line

A line's behavior in the steady state can be described by means of the characteristic parameters combining resistance, inductance and capacitance. The expression "line" serves as a general term for overhead lines and underground cables which basically exhibit the same behavior. The three characteristic parameters just mentioned represent constants which apply at any point along the length of the line (quantities per unit length). At the lengths of 100 – 400 km (62.15 - 248.6 mi) typical of extra-high voltage lines, however, concentrations of elements can be considered without any significant losses in accuracy, thus resulting in the following three-phase equivalent circuit diagram:

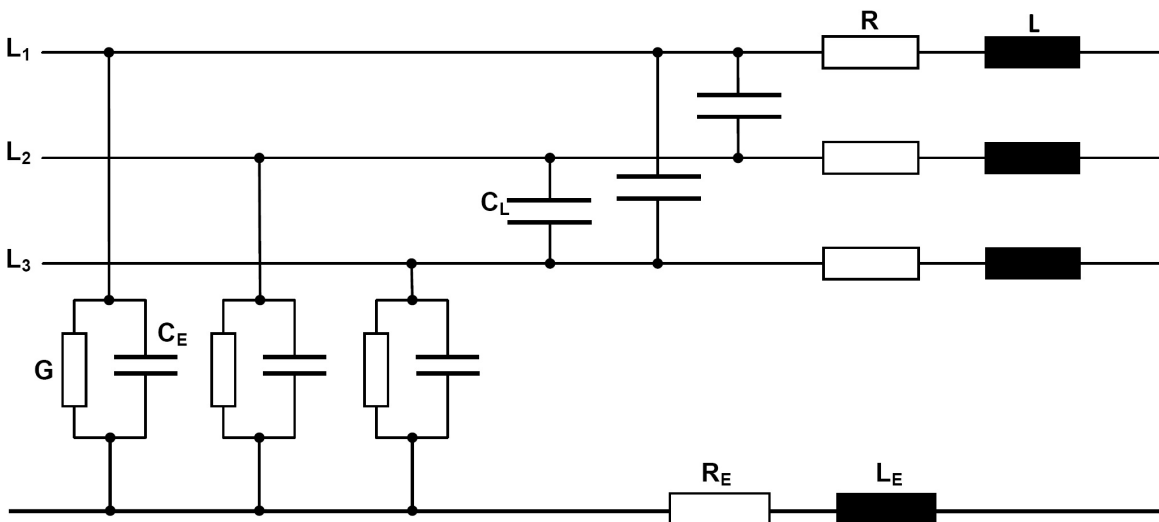

Figure 1:

Three-phase equivalent circuit diagram of a power transmission line including concentrated elements

The active resistance R is determined by the conductor's material, cross-section and, naturally, length. The inductance L accounts for the magnetic field generated when a current flows through a conductor loop. A distinction is made between two types of capacitance: The line-to-line capacitance C_L is the capacitance between any two outer conductors, while C_E is the capacitance between the outer conductors and earth. The dissipation losses caused by leakage currents and, in particular, corona losses at high currents, are described by the conductance G . Finally, the characteristics of the return conductor (earth, earth wire) are represented by means of the parameters R_E and L_E . The line model consists of a 380-kV overhead line comprising groups of four and possessing a cross-section of $4 \times 300 \text{ mm}^2$ (aluminium). The model has the following longitudinal data (constants):

$$R' = 0.024 \Omega / \text{km}, L' = 0.77 \text{ mH} / \text{km}, C_B' = 13.07 \text{ nF} / \text{km}.$$

Single-phase representation is sufficient if the operating conditions are symmetric (identical voltages and currents for the three outer conductors). The line and earth capacitances at various voltages are converted into a new variable designated the *effective* or *working capacitance C_B . In this case: $C_B = C_E + 3 C_L$. It must be noted that underground cables have a much higher working capacitance than overhead lines. Regardless, representation with the help of a Π -element is more advantageous than the T-type equivalent circuit diagram shown above, the transverse elements being applied in a proportion of half each at the beginning and end of the diagram. This results in the following representation:*

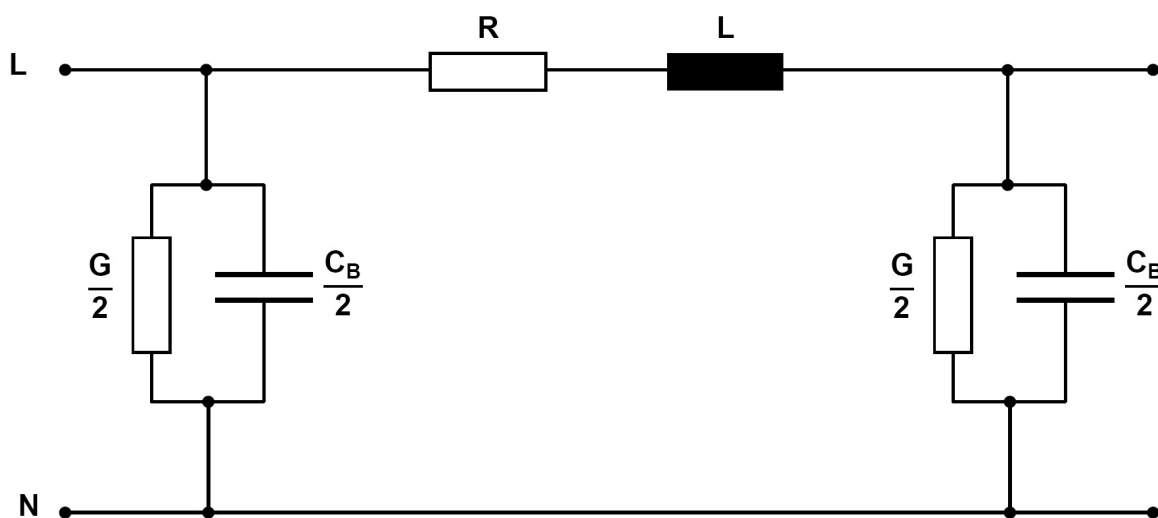

Figure 2:
Single-phase equivalent circuit diagram of a Transmission line

To keep transmission losses within limits, efforts are made in practice to minimize the conductor resistance R and maximize the conductance G . Accordingly, $R \ll \omega L$ and $G \gg \omega C_B$.

Lines with these properties are described as *low-loss*. If R and G can be neglected entirely, one speaks of a *lossless* line. Though lossless lines cannot be realized in practice, the simplifications above become more accurate as the considered voltage level rises. This applies especially when investigating the *steady-state* response. For rough calculations confined to essential aspects, the equivalent circuit diagram shown below can be used to represent operation at zero power loss.

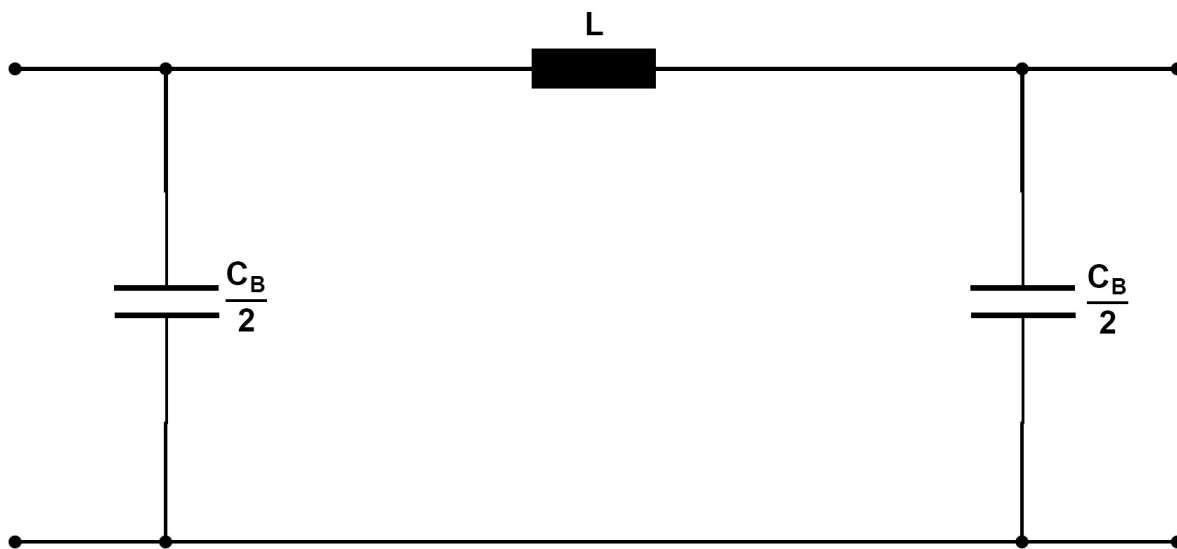
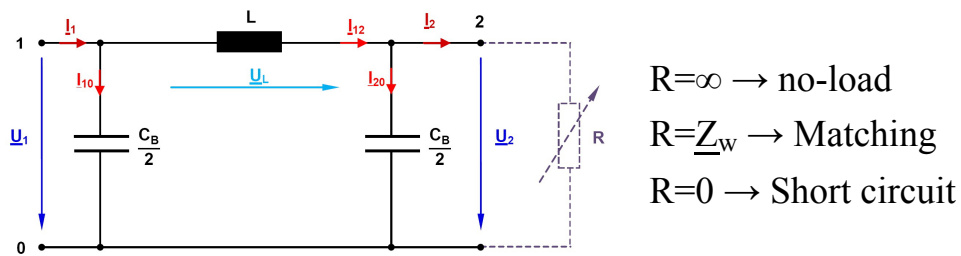

Figure 3:
Single-phase equivalent circuit diagram of a lossless line.

For further investigations (e.g. determination of efficiency and transmission losses), it is necessary to at least consider the active resistance in addition to R . For exact modeling (e.g. when investigating processes involving traveling waves), a line of length l should be composed of an infinite number of π -elements each with a differential length of dl . This representation can be used to derive *line equations* needed for precise calculations of long lines. These equations include a factor designated *characteristic impedance* Z_w . Assuming a lossless line, this factor is calculated using the equation $Z_w = \sqrt{L / C_B}$. If a line is subjected to a resistive load equal in magnitude to the characteristic impedance, one speaks of *matching*. This state is ideal in terms of transmission losses. A variable load resistor at the end of the line can be used to clearly demonstrate the three states comprising no-load, matching and (symmetric) short circuit.



$R = \infty \rightarrow$ no-load
 $R = \underline{Z}_W \rightarrow$ Matching
 $R = 0 \rightarrow$ Short circuit

Figure 4:

Lossless Transmission line in various load states

In the case of single-phase representation, it is always necessary to account for *star voltages* (Y), i.e. those occurring between a phase and the neutral point (the voltage measured between two outer conductors is designated *line-to-line voltage* V_Δ here). On transition to a three-phase system, all powers calculated in the single-phase representation must be multiplied by a factor of 3 to obtain the total power. The designations listed below are used (complex variables are underlined).

V_1, V_2 : Voltages respectively at the line's start and end.

\underline{V}_L : Voltage drop along the line.

$\underline{I}_1, \underline{I}_2$: Currents respectively at the line's start and end.

$\underline{I}_{10}, \underline{I}_{20}$: Currents through the transverse branches respectively at the line's start and end.

\underline{I}_{12} : Current through the line's longitudinal branch.

In the *no-load* state, the finishing resistance R at the line's end is infinitely large, so that the current $I_2 = 0$. The processes taking place in circuits operating at sinusoidal voltages are visualized by means of *phasor diagrams*. These diagrams enable a simultaneous representation of the magnitude and phase angle of the AC quantities under examination. Phasors can be added or subtracted graphically, thereby allowing a clear display, for instance, of voltage drops in networks. All phasors rotate at an angular speed denoted by ω , their diagrams serving to provide "snapshots" of the system under consideration. These displays are purely of a qualitative nature and not true-to-scale, and therefore only intended for illustration. The related, numerical values can be determined individually with the help of complex calculations. In the combined current/voltage phasor diagrams below, the voltage vector at the end of the line is defined arbitrarily as the reference phasor, and drawn in the same direction as the real axis. Furthermore, as is common practice in energy technology, the display's coordinate system is rotated by $+90^\circ$ so that the real axis points in the y-direction. The current/voltage phasor diagram below describes the no-load state.

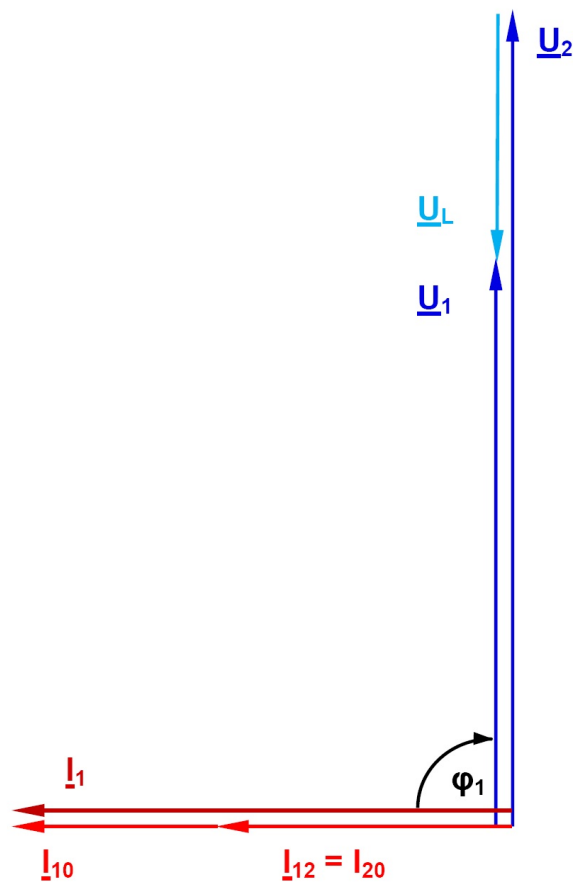

Figure 5:
Current/voltage phasor diagram of a lossless line in the no-load state

The phasor diagram shows that in this operating state, the voltage at the line's end is higher than the voltage at the line's start. This is due to the working capacitance and known as the *Ferranti effect*. The voltage at the line's end has risen disproportionately with respect to the line's length; efforts are therefore made to avoid this operating state in practice. The current flowing in the no-load state is termed the *charging current*, and the associated reactive power the *charging power*. As already mentioned, underground cables have a higher working capacitance than overhead lines. The effects described earlier are much more pronounced here. In the event of *matching*, the load resistance R is exactly equal to the characteristic impedance. The power consumed by the active resistance is termed *natural power*. The resultant current is just high enough so that the reactive power consumption attributable to the line inductance is exactly equal to reactive power generated by the working capacitance. Assuming that the line is lossless, it consumes or generates no reactive power whatsoever, and the active power it draws from the upstream connected network only add up to the natural power. Furthermore, the voltage at the start of the line in this case has the same magnitude as the voltage at the end of the line. The next phasor diagram describes this situation.

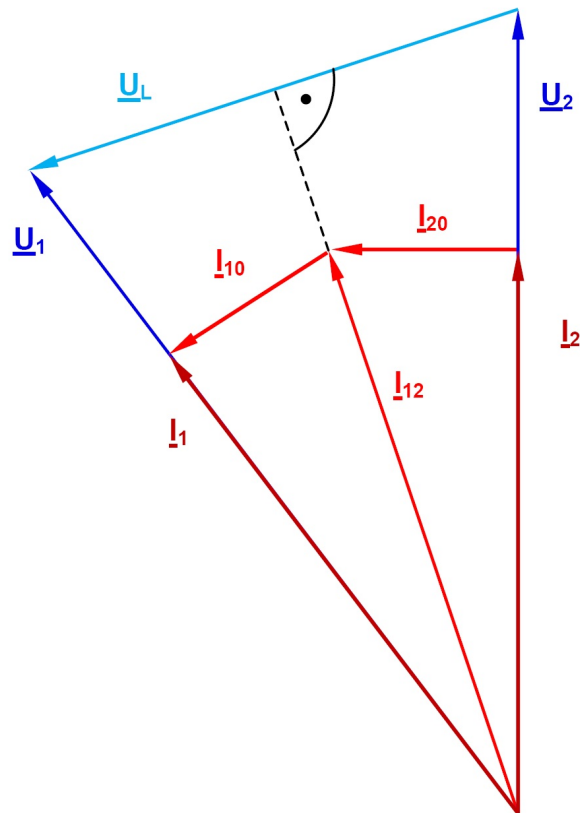

Figure 6:
Current/voltage phasor diagram of a lossless line during matching
(termination with the characteristic impedance)

Due to the conductive material of which it is made, every real transmission line also has an active resistance, which is responsible for the transmission losses. These are equal to the difference between the supplied and consumed powers. A transmission system's *efficiency* is defined as the ratio between the active powers at the system's output and input. Because no reactive power needs to be transmitted in the event of matching, the efficiency is maximized in this case. Since the value of a line's load is determined by the behavior of the consumers connected to the line, matching occurs very rarely and randomly. However, *reactive power compensation* is also available as an option for minimizing transmission losses. In the case of a (three-pole) *short circuit*, the load resistance R has the value 0. The current then flowing is limited only by the line impedance (assuming that the line inductance results in lossless transmission) and therefore much higher than the values occurring during normal operation. This must be detected and isolated as soon as possible by the network protection devices. The phasor diagram below describes this situation.

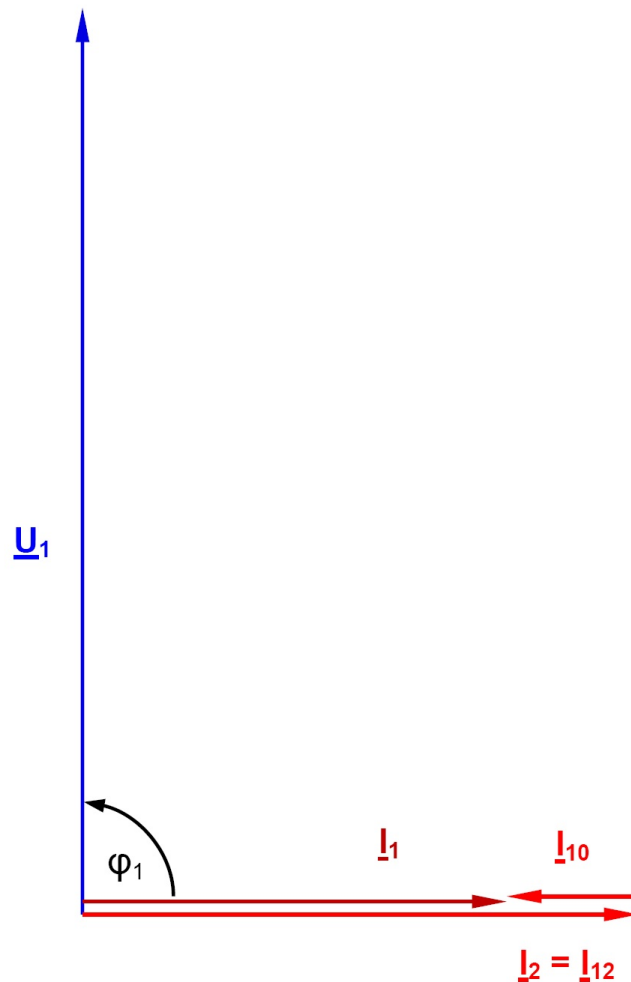

Figure 7:

Current/voltage phasor diagram of a lossless line in the event of a short circuit at the line's end

Finally, we will look at the phasor diagram in the case of the resistive/inductive loads such as those occurring most frequently during real-life operation. For a more precise representation, a *low-loss* line is assumed here.

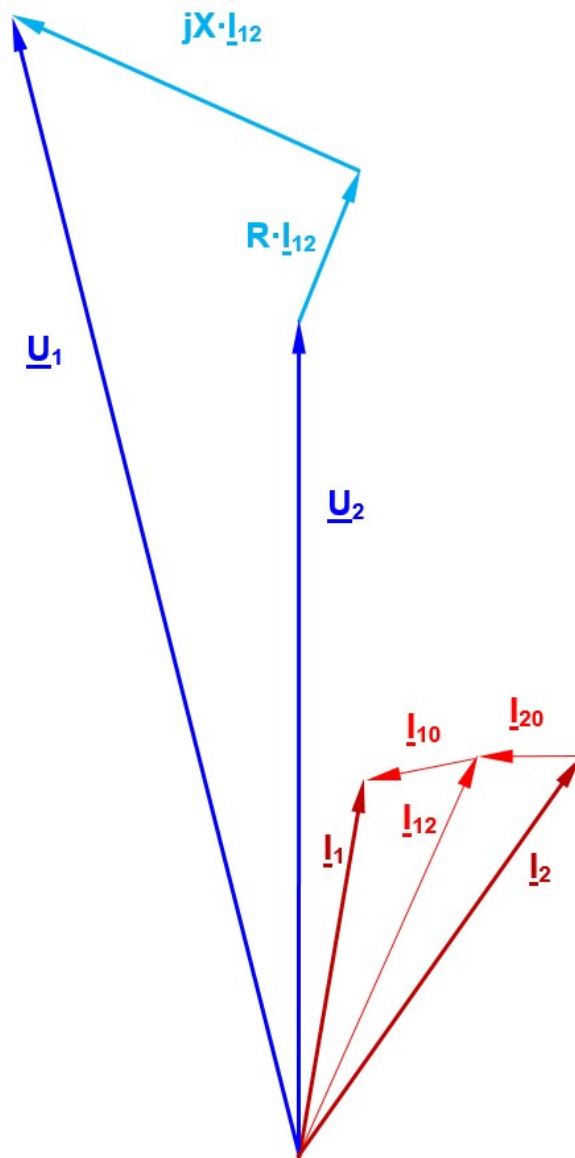

Figure 8:

Current/voltage phasor diagram of a low-loss line in the case of a mixed (resistive/inductive) load

The resultant current I_2 through the load incorporates a resistive and an inductive component in accordance with the ratio of the load's active and reactive powers. In practice, the influence of the capacitances at the line's end is (qualitatively) lower than that indicated in the phasor diagram here, i.e. I_2 and I_{12} are approximately equal. As the reactive power rises, so does the longitudinal current through the line and, consequently, the losses produced by the line resistance R . To minimize these losses, electricity supply companies define certain limiting values for the reactive power and power factor $\cos \varphi$.

Accordingly, it is common to demand a surcharge on electricity rates (reactive power clause) from $\cos \varphi$ values below 0.8. One alternative for the customer is to compensate the (usually) inductive reactive power by means of capacitors connected in parallel. The power triangle shown below illustrates the relationships involved here.

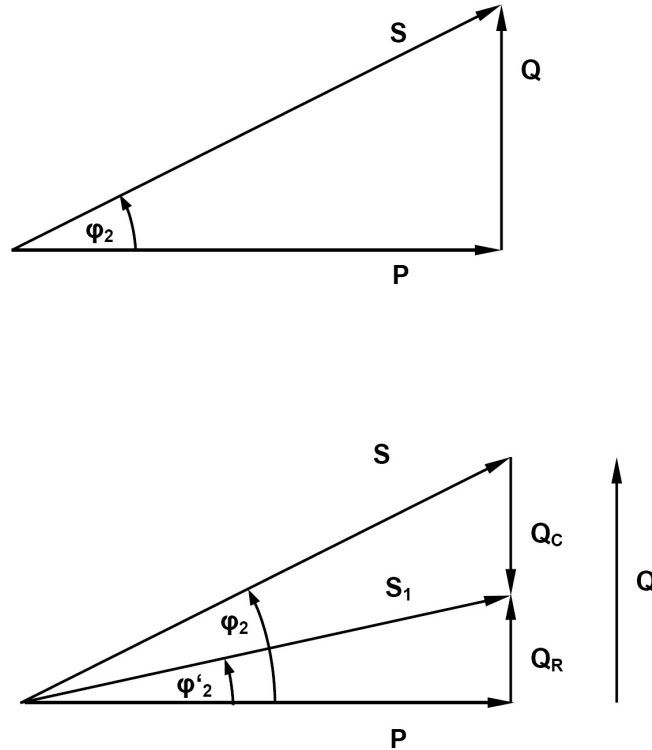

Figure 9:

Power ratios with an uncompensated and partly compensated load

P is the active power, Q the reactive power, and S the apparent power. To reduce the apparent power and, consequently, the apparent current, the reactive power can be lowered, for instance, from its original value Q to a residual value Q_R . This is equivalent to improving the power factor from $\cos \varphi_2$ to $\cos \varphi'_2$. As indicated in the diagram, the compensatory reactive power Q_C needed for this is therefore:

$$Q_C = P * (\tan \varphi_2 - \tan \varphi'_2), \text{ where } P \text{ is the total consumed active power.}$$

The equation indicates that the compensatory capacitance is load dependent. Its three individual capacitors C connected in star configuration are determined by:

$$C = Q_C / (\omega * V_N^2)$$

The last equation assumes that the nominal voltage is present across the load. Moreover, half the working capacitance present at the line's end also contributes very slightly toward compensation. However, both influences are usually ignored during the design of compensatory mechanisms. For full compensation, ϕ_2 must be zero, so that: $QC = P * \tan \phi_2$.

Usually, it is sufficient to perform compensation leaving a residual reactive power at which a surcharge for reactive work is just avoided. Besides this *parallel compensation* (of relevance to consumers), there is also the possibility of *series compensation* in the case of very long lines. Performed by the transmission network's operator, this kind of compensation is meant to reduce the effect of the longitudinal conductivity L and, therefore, the voltage drop V_L (refer to Figure 4).

The next phasor diagram illustrates the action of series compensation (to simplify the working capacitance was dropped).

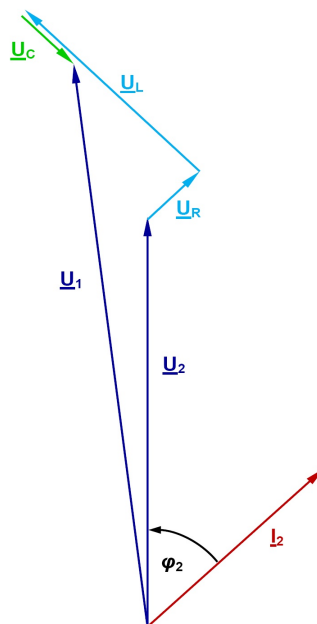
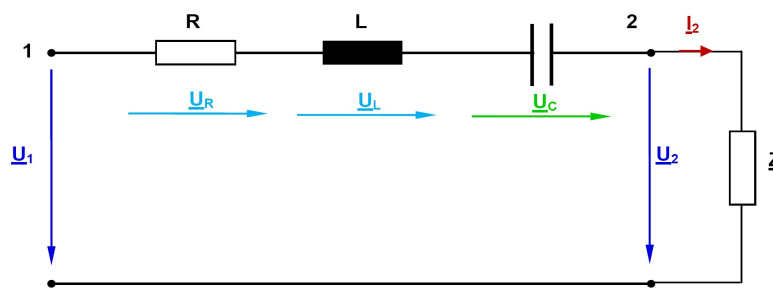

Figure 10:
Series compensation: Circuit diagram and associated phasor diagram

For the sake of simplicity, the line capacitances are not considered because they have practically no influence on the process of compensation. If the entire voltage drop V_L is to be compensated, the three capacitors C must have the following value:

$$C = 1 / (\omega^2 * L) = 1 / (\omega * X_L)$$

In practice, only *partial compensation* is often performed to a level of 30% – 60 % (capacitor reactance in relation to line reactance X_L). Wherever possible, the three capacitors are positioned roughly halfway between the two line ends.

Following are some numerical examples:

A. No Load

To determine the voltage at the line's start ($V_1 = 220$ V), it is used the voltage at line's open end ($V_2 = 224$ V). The calculations shown next apply according to Figures 4 and 5 (all calculations are carried out for single-phases on the basis of the associated phasor diagram).

For a line length of 150 km (93.22 mi):

$$I_{20} = V_2 * \omega C_B / 2 = 224 \text{ V} * 377 \text{ s}^{-1} * 1 \text{ } \mu\text{F} = 0.084 \text{ A}$$

$$V_L = X * I_{20} = 3.64 \text{ V}$$

$$V_1 = V_2 - U_L = \underline{220.36 \text{ V}}$$

For a line length of 300 km (186.45 mi):

$$I_{20} = V_2 * \omega C_B / 2 = 236 \text{ V} * 377 \text{ s}^{-1} * 2 \text{ } \mu\text{F} = 0.178 \text{ A}$$

$$V_L = X * I_{20} = 15.43 \text{ V}$$

$$V_1 = V_2 - V_L = \underline{220.5 \text{ V}}$$

The charging power can be find out with sufficient precision assuming that the voltages at the start and end of the line are identical.

$$\text{In this case: } Q_c = 3 * (V_N / \sqrt{3})^2 * \omega * C_B = V_N^2 * \omega * C_B$$

For a line length of 150 km (93.22 mi):

$$Q_c = (380 \text{ V})^2 * 377 \text{ s}^{-1} * 2 \text{ } \mu\text{F} = \underline{108.87 \text{ var}}$$

For a line length of 300 km (186.45 mi):

$$Q_c = (380 \text{ V})^2 * 377 \text{ s}^{-1} * 4 \text{ } \mu\text{F} = \underline{217.75 \text{ var}}$$

B. Mixed Load

Single-phase calculations for a line length of 150 km (93.22 mi) on the basis of the phasor diagram in Figure 8 and Figure 4 as reference. The load's active power $P_2 = 500$ W and the line's end voltage $V_{LL2} = 342$ V results in the following active current:

$$I_{2 \text{ active}} = P_2 / (\sqrt{3} * V_{LL2}) = 500 \text{ W} / (1.732 * 342 \text{ V}) = 0.844 \text{ A}$$

The inductive load of 1.2 H results in the following reactive current:

$$I_{2 \text{ reactive}} = V_{LL2} / (\sqrt{3} * \omega L) = 0.436 \text{ A}.$$

Accordingly, the complex current at the end of the line is:

$$\underline{I}_2 = (0.844 - j 0.436); \text{ value of } I_2 = \underline{0.950 \text{ A}}.$$

The following applies to the load's power factor: $\tan \varphi_2 = I_{2 \text{ reactive}} / I_{2 \text{ active}} = 0.52$ and $\cos \varphi_2 = \underline{0.89}$.

The transverse current due to half the working capacitance at the end of the line is:

$$\underline{I}_{20} = \underline{V}_2 * (j \omega C_B / 2) = j 0.074 \text{ A (star voltage (Y) } V_2 = 197.46 \text{ V)}.$$

The longitudinal current along the line is $\underline{I}_{12} = \underline{I}_2 + \underline{I}_{20} = (0.844 - j 0.362) \text{ A}$.

Consequently, $\underline{V}_1 = \underline{V}_2 + (R + j X) * \underline{I}_{12}$.

If $R = 3.6 \Omega$ and $X = 43.35 \Omega$ (line values) are used, then $\underline{V}_1 = (216.2 + j 35.28) \text{ V}$ and $V_{LL1} = (374.44 + j 61.049) \text{ V}$.

The voltage at the start of the line is $V_{LL1} = \underline{379.5 \text{ V}}$

The transverse current due to half the working capacitance at the start of the line is:

$$\underline{I}_{10} = \underline{V}_1 * (j \omega C_B / 2) = (- 0.013 + j 0.082) \text{ A}$$

Consequently, the current flowing through the line is:

$$\underline{I}_1 = \underline{I}_{12} + \underline{I}_{10} = (0.831 - j 0.280) \text{ A}; \text{ value of } I_1 = 0.877 \text{ A}.$$

The (total) apparent power consumed by the line is:

$$\underline{S} = 3 * \underline{V}_1 * \underline{I}_1^* \quad (\underline{I}_1^* \text{ is the conjugated, complex value of } I_1).$$

After multiplication, the active power is:

$$P_1 = \underline{513 \text{ W}} \text{ and the reactive power is } Q_1 = \underline{263 \text{ var}}.$$

C. Series Compensation

Series compensation can be performed in the case of long transmission lines to avoid excessively high voltage drops along them. The load at the end of a long line causes an impermissible high voltage drop. A series capacitor can be used to reduce this drop as seen in Figure 10. Three individual capacitances with the value $C = 1 / (\omega * X_L)$ are required for full compensation. At a length of 150 km (93.22 mi), the line model has a reactance $X_L = 43.35 \Omega$, so that $C = 61 \mu\text{F}$.

Parallel and Series Connections of Transmission Lines

Large power plants are usually located at a distance from load clusters. A widespread supply of electricity consequently requires the presence of a line network combining several voltage levels, depending on the transmission distances. Familiar network types include the radial, ring and meshed networks:

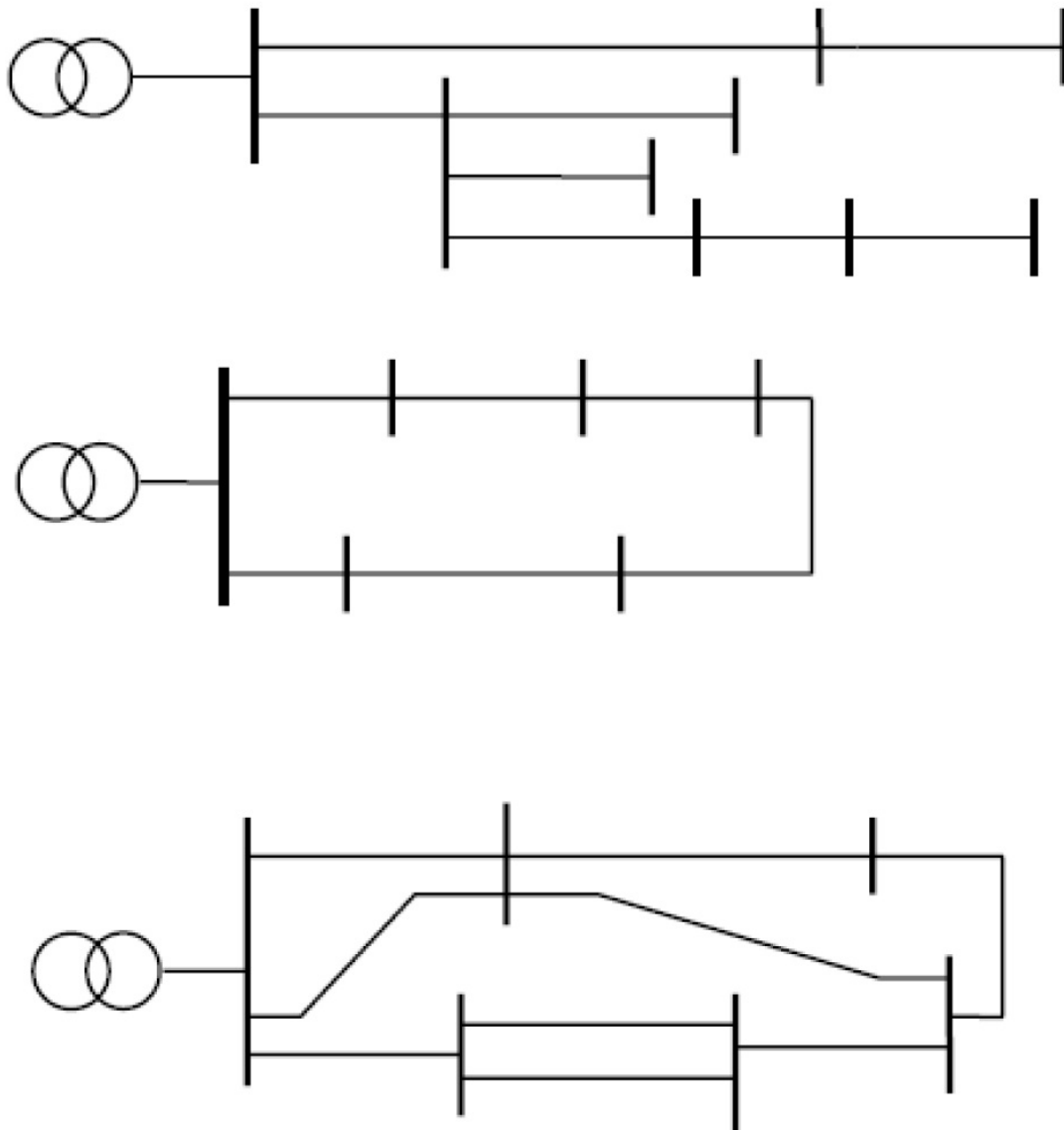

Figure 11:

Types of network for supplying electrical power (from top: radial network, ring network, meshed network)

The radial network is the simplest and cheapest way of supplying customers. However, a failure of a single line here affects all the loads connected downstream from it. Better performance is delivered by ring networks, in which each consumer is supplied from two sides. In the event of a fault, the network protection mechanisms disconnect only the affected line, so that the customers continue to be supplied.

For this, however, the transmission lines must provide a sufficient capacity. More convenient yet is the mesh network, in which each consumer can be reached via several paths. If a power plant fails in a properly designed network of this kind, the remaining feed units can step in as replacements. As the mesh becomes denser and supply becomes more dependable, however, the required investment rises dramatically and the necessary protective facilities become increasingly complex

Networks operating at high and ultra-high voltages (integrated power grids) are usually planned and operated on the *n-to-1 principle*, according to which any *one* of a total of n items of equipment in a network may fail without disrupting normal operations. Only the occurrence of a second fault can disrupt the power supply to individual customers or overload equipment, which must then be disconnected. However, experience has shown that the probability of two faults occurring simultaneously is extremely low.

Elaborate calculations are needed to determine a network's optimal topology (i.e. type and number of line connections between the individual facilities). Load flow calculations clarify the cross-sections necessary to transmit the specified power levels at minimal loss. Short-circuit calculations are used to determine which currents would flow in the event of a failure, and which protective devices could serve to minimize the duration and extent of the failures. Even complex network structures can be traced back to simple, basic circuits whose operation must be known to the planner.

To derive the laws governing series and parallel connections of transmission lines, it is first necessary to know the equivalent circuits of the involved components. In investigations confined to trouble-free operation, the line's three phases are loaded symmetrically. In this case, it is sufficient to consider a single phase representation in the form of a π -element shown in Figure 12.

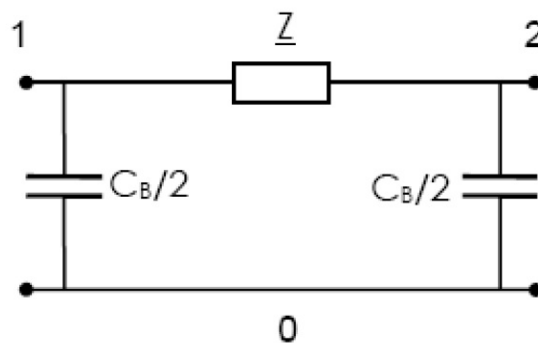

Figure 12:
Equivalent circuit of a transmission line (single-phase representation)

The longitudinal impedance Z is comprised of the line resistance R and line inductance L . It is calculated with the equation $Z = R + j X$, where $X = \omega L$. The working capacitance C_B is applied in two equal halves each to the start and end of the line to avoid an additional node in the middle of the line.

In reality, these parameters are distributed evenly as constants over the line's entire length. Details and figures on the constants are provided in the section titled "Three-phase Overhead Power Transmission Line".

The equivalent circuit diagram above reflects the situation sufficiently accurately, as long as only steady-state operating conditions are considered and the lines are not excessively long. The line models used in the experiments are designed as three-phase π -networks with possible lengths of 150 and 300 km (93.22 and 186.45 mi). The specific values (constants) of the used lines are: $R' = 0.024 \Omega/\text{km}$, $X' = 0.289 \Omega/\text{km}$ and $C_B' = 13.33 \text{ nF}/\text{km}$. To demonstrate typical properties, it is sufficient to consider a transmission path terminated by means of a mixed, resistive-inductive load. In principle, the findings obtained here also apply to other types of load. A resistive-inductive load results in the phasor diagram shown below, indices 1 and 2 respectively indicating the line start and end, 0 representing the return conductor (earth).

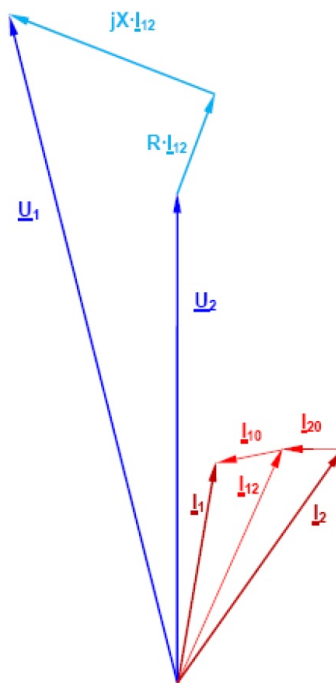

Figure 13:
Phasor diagram of a line with a resistive-inductive load

The vector diagram is qualitative in nature, i.e. not true to scale. \underline{V}_2 and \underline{I}_2 are the (complex) voltage and current at the line's end, these values being assumed during calculation and plotting. The voltage is a star voltage (between one phase and the neutral point). The values \underline{V}_1 and \underline{I}_1 at the start of the line are determined by considering the voltage drops across the longitudinal impedance \underline{Z} and the currents through the shunt arms (capacitances) at the two line ends.

Series connection

This circuit consists of two or more lines connected in series. Forming the basis for developing radial networks, the circuit is characterized by an identical current flowing through all lines. In practice, this means that a series connection can transmit no more power than allowed by the line with the smallest cross-section. An aggregation of the line constants into concentrated elements results in transverse components at the modeled line's start and end. Consequently, the current at the end of the first line segment deviates slightly from the current flowing into the next segment. However, this systemic error only has a minor impact on calculations and subsequent measurement results.

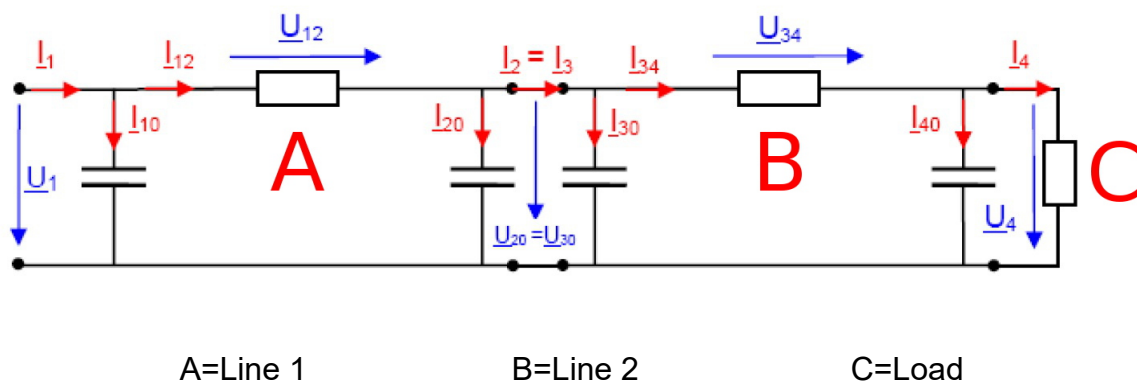

Figure 14:
Series Connection of Two Lines

To trace the circuit's output parameters (load's star voltage \underline{V}_4 and current \underline{I}_4) back to its input parameters \underline{V}_1 and \underline{I}_1 , we proceed in two steps:

Half the working capacitance of line 2 is connected in parallel with the load. The current I_{40} must be added to the load current to obtain the current I_{34} through the line. This makes it possible to determine the voltage drop V_{34} along line 2 and the voltage $V_{20} = V_{30}$ at the point connecting both lines. Once this voltage is known, it becomes possible to derive the current I_{30} flowing via half the working capacitance of line 2 (at the start). Both currents together result in the value I_3 through the line. In the next step, the current I_{20} flowing via half the working capacitance of line 1 (at the end) can be determined. As in the case of line 2, we obtain the current I_{12} through line 1, the voltage drop V_{12} along line 1, and the voltage V_1 at the start of the line. After that, it is possible to calculate the current I_{10} flowing via half the working capacitance at the start of line 1. Together with the current I_{12} , this results in the total current I_1 consumed by the system.

As a rough approximation, a series connection of two lines can also be modeled by adding together the individual values of the elements, i.e. $R = R_1 + R_2$, $L = L_1 + L_2$ and $C_B = C_{B1} + C_{B2}$. The two lines can then be considered as a single, longer line.

Parallel Connection

In this case, two or more lines are connected in parallel to enable a transmission of higher powers. Forming a basis for developing mesh networks, this kind of circuit is characterized by equal voltage drops across all lines. In practice, this means that the line of the lowest impedance conducts the highest amperage. Only in the case of two lines with identical ratings and lengths is the total current divided into equal halves.

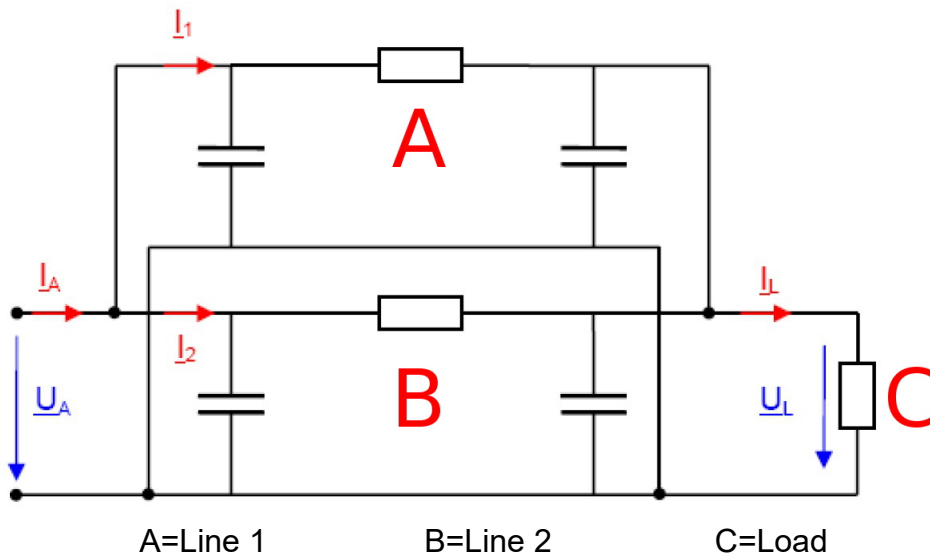

Figure 15:
Parallel Connection of Two Lines

A parallel connection can be represented simply by an equivalent impedance because no new nodes arise between the two lines. The two line impedances \underline{Z}_1 and \underline{Z}_2 form the equivalent impedance $\underline{Z} = R + j X$, where:

$\underline{Z} = (\underline{Z}_1 * Z_2) / (\underline{Z}_1 + Z_2)$, whose resolution results in:

$$R = [R_1 R_2 (R_1 + R_2) + R_1 X_2^2 + R_2 X_1^2] / [(R_1 + R_2)^2 + (X_1 + X_2)^2] \text{ and}$$

$$X = [X_1 X_2 (X_1 + X_2) + R_1^2 X_2 + R_2^2 X_1] / [(R_1 + R_2)^2 + (X_1 + X_2)^2]$$

A phasor diagram need not be specified for this circuit because its conditions are identical to those shown in Figure 13, except that the parameters have changed. Two lines of equal lengths and ratings connected in parallel each conduct half the load current.

Following are some numerical examples:

A. Series Connection

Calculations are performed for a single phase on the basis of the phasor diagram in Figure 13, the values for line 2 being determined first. Figure 14 is used as a reference with the line parameters of two transmission lines of 150 Km (93.22 mi) in series.

The load's active power $P_4 = 590 \text{ W}$ at the (star) voltage $V_{LN2} (\underline{V}_4) = 206 \text{ V}$ is employed to find the active current:

$$I_{4 \text{ active}} = P_4 / (3 * V_{LN2}) = 590 \text{ W} / (3 * 206 \text{ V}) = 0.955 \text{ A}$$

The reactive power $Q_4 = 187 \text{ Var}$ gives the following: $I_{4 \text{ reactive}} = Q_4 / (3 * V_{LN2}) = 0.301 \text{ A}$

Accordingly, the complex current at the line's end is $\underline{I}_4 = (0.955 - j 0.301) \text{ A}$;
value of $I_4 = 1.0 \text{ A}$

The transverse current via half the working capacitance at the line's end is:

$$\underline{I}_{40} = \underline{V}_4 * (j \omega C_B / 2) = j 0.078 \text{ A}$$

Accordingly, the longitudinal current is: $\underline{I}_{34} = \underline{I}_4 + \underline{I}_{40} = (0.955 - j 0.223) \text{ A}$

The voltage at the line's start is: $\underline{V}_3 = \underline{V}_4 + (R + j X) * \underline{I}_{34}$

If $R = 3.6 \Omega$ and $X = 43.35 \Omega$ (line values) are used, then:

$$\underline{V}_3 (\underline{V}_{30}) = (219.11 + j 40.60) \text{ V}; \text{ value of } V_3 = \underline{222.83 \text{ V}}$$

The transverse current via half the working capacitance at the start of the line is:

$$\underline{I}_{30} = \underline{V}_3 * (j \omega C_B / 2) = (- 0.015 + j 0.083) \text{ A}$$

Consequently, the current flowing through the line is: $\underline{I}_3 = \underline{I}_{34} + \underline{I}_{30} = (0.937 - j 0.140) \text{ A}$;
-value of $I_3 = \underline{0.95 \text{ A}}$

The (total) apparent power consumed by the line is: $\underline{S} = 3 * \underline{V}_3 * \underline{I}_3^*$
(\underline{I}_3^* is the conjugated, complex value of I_3).

After multiplication, the active power is $P_3 = \underline{634.7 \text{ W}}$

The reactive power is $Q_3 = \underline{209.4 \text{ var}}$

For line 1, the outcome on the basis of the calculated values above, at its end is:

$$V_2 (V_{20}) = V_3 = 223 \text{ V}, P_2 = P_3 = 635 \text{ W}, Q_2 = Q_3 = 210 \text{ var}$$

$$\underline{I}_2 = (0.949 - j 0.314) \text{ A}, \underline{I}_{20} = j 0.084 \text{ A}, \underline{I}_{12} = (0.949 - j 0.230) \text{ A}$$

$$\underline{V}_1 = (236.4 + j 40.31) \text{ V}; \text{ value of } V_1 = \underline{239.8 \text{ V}}$$

Moreover, $\underline{I}_{10} = (-0.015 + j 0.089) \text{ A}$ and $\underline{I}_1 = (0.934 - j 0.141) \text{ A}$

Value of $I_1 = 0.94 \text{ A}$

The resultant power levels are $P_1 = 679.4 \text{ W}$ and $Q_1 = 222.9 \text{ var}$

B. Parallel Connection

Calculations are performed for a single phase on the basis of the phasor diagram in Figure 13, the values for line 1 being determined. Figure 15 is used as a reference with the line parameters of two transmission lines of 300 Km (186.45 mi) and 150 Km (93.22 mi) in parallel. According to the equations derived in Section "Parallel Connection," the equivalent resistance $R_{//} = 2.4 \Omega$ and the equivalent reactance $X_{L//} = 28.9 \Omega$. In the case of two lines connected in parallel, their working capacitances add up to $C_{B//} = 6 \mu\text{F}$.

The load's active power $P_L = 969 \text{ W}$ and reactive power $Q_L = 321 \text{ Var}$ at the (star) voltage $V_{LLN} (V_L) = 213 \text{ V}$ is employed to find the active current:

$$I_{L \text{ active}} = P_L / (3 * V_{LLN}) = 969 \text{ W} / (3 * 213 \text{ V}) = 1.516 \text{ A}$$

$$I_{L \text{ reactive}} = Q_L / (3 * V_{LLN}) = 0.502 \text{ A}$$

Accordingly, the complex current at the load is $\underline{I}_L = (1.516 - j 0.502) \text{ A}$; value of $I_L = 1.598 \text{ A}$

The transverse current via half the working capacitance of parallel lines:

$$\underline{I}_{20} = \underline{V}_L * (j \omega C_{B//} / 2) = j 0.241 \text{ A}$$

$$\underline{I}_{12} = \underline{I}_L + \underline{I}_{20} = (1.516 - j 0.261) \text{ A},$$

$$\underline{V}_1 = \underline{V}_L + (R_{//} + j X_{L//}) * \underline{I}_{12} = (224.18 + j 43.19) \text{ V}; \text{ value of } V_1 = 228.3 \text{ V},$$

$$\underline{I}_{10} = (-0.049 + j 0.253) \text{ A},$$

$$\underline{I}_A = \underline{I}_{10} + \underline{I}_{12} = (1.467 - j 0.037) \text{ A}; \text{ value of } I_A = 1.48 \text{ A}$$

The (total) apparent power consumed by the two lines is: $S_T = 3 * \underline{V}_1 * \underline{I}_A^*$
(\underline{I}_A^* is the conjugated, complex value of I_A).

After multiplication, the active power is $P_T = \underline{991.4 \text{ W}}$

The reactive power is $Q_T = \underline{165.2 \text{ var}}$

Three-phase Transmission Line with Earth Fault Compensation

Despite the latest technology incorporated by electric power plants, it is still not possible to rule out failures and interruptions caused by a variety of factors such as lightning strikes, damage to overhead lines by snow or bad weather, damage to cables by construction work or rodents, heating due to overload, aging of equipment etc. These factors can lead to various types of faults and repercussions on the equipment and protective mechanisms present in the network. It should also be noted that neutral-point treatment significantly influences fault current values and associated failures caused by voltage spikes.

The method of symmetric components

Single-phase representation is sufficient for considering a three-phase line exclusively in the symmetric mode. However, this single phase representation becomes inadequate on occurrence of an imbalance, especially if caused by a failure.

Among the various mathematical calculation types available here, the method of symmetric components is now in widespread use. It is based on the concept of breaking down the asymmetric three-phase system initially into individual, mutually independent systems. This procedure is known as *analysis*. It results in two symmetric systems defined respectively as a positive sequence and a negative sequence. A third system, occurring only under certain conditions, is called the zero sequence. This system is inapplicable, for instance, if the three-phase system purely consists of three phases without a return conductor. In practice, however, most three-phase systems contain a fourth conductor (earth wire, earth, cable jacket) as the return line.

The individual systems (component systems) therefore formed are initially independent of each other. If an imbalance occurs in the form of a fault, its nature determines the resultant characteristics of the systems' joint circuitry.

The positive, negative and zero sequences are introduced next.

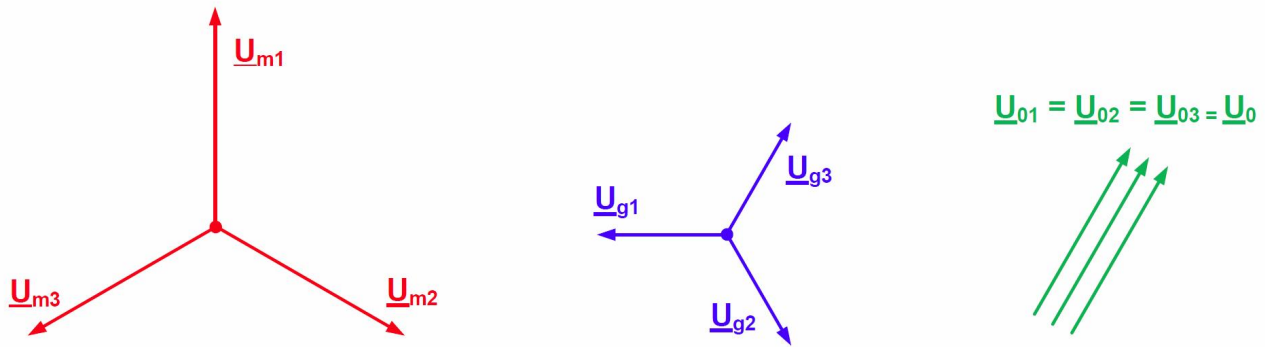

Figure 16:

Definition of positive, negative and zero sequences

Positive sequence: This sequence comprises three phasors equal in magnitude but phase-shifted mutually by 120° in the clockwise direction. We will identify each of the three phasors by an index m .

Negative sequence: This sequence comprises three phasors equal in magnitude but phase-shifted mutually by 120° in the counterclockwise direction. We will identify each of the three phasors by an index g .

Zero sequence: This sequence comprises three phasors equal in magnitude and in phase with each other. We will identify each of the three phasors by an index 0 .

Conversely, one phasor each from a positive, negative and - if necessary - zero sequence can be used to compose an asymmetric three-phase system. Called *synthesis*, this process involves *linear superposition*.

Analysis and synthesis can be performed both graphically and mathematically. The graphic technique here serves merely to illustrate synthesis, preference otherwise being given to the computational method.

Illustrated below is the formation of an asymmetric voltage system's phasors \underline{V}_1 , \underline{V}_2 and \underline{V}_3 from the phasors of arbitrarily selected positive, negative and zero systems.

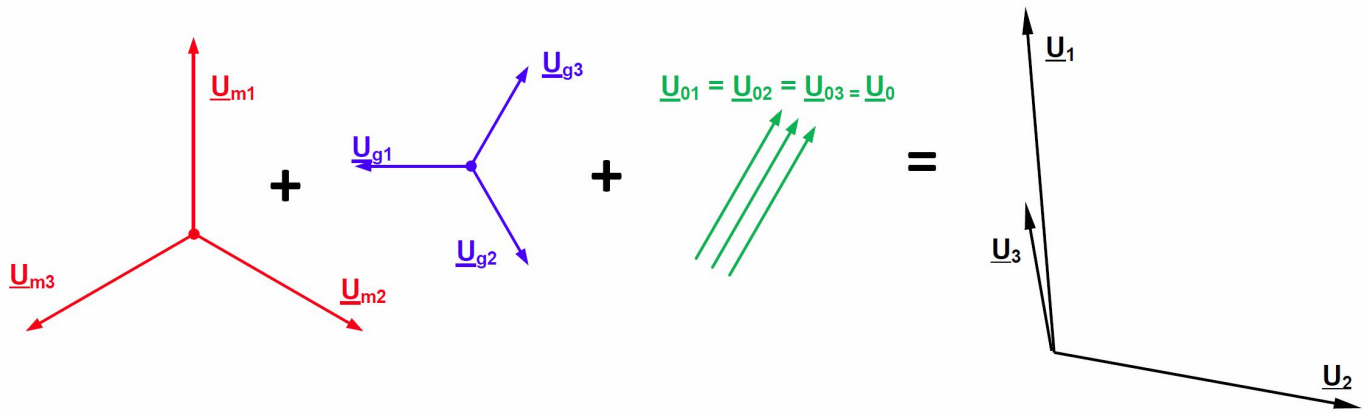

Figure 17:

Synthesizing an asymmetric system from positive, negative and zero sequences

The derivations further below are carried out with an arbitrary system of voltage phasors; the procedure applies similarly to systems comprising current phasors.

For a mathematical treatment, one defines a *complex rotation operator* \underline{a} enabling a simplified description of a component system's individual phasors. The positive, negative and zero sequences are each represented only by a single phasor here; the other two phasors can be derived from the reference phasor with the help of the complex rotation operator.

The rotation operator \underline{a} has the following value:

$$\underline{a} = -1/2 + 1/2 \sqrt{3} j = e^{j120^\circ}$$

Multiplying a phasor by \underline{a} therefore rotates the phasor by $+120^\circ$ while leaving its length unchanged.

The relationships shown next apply furthermore to \underline{a} .

$$\underline{a}^2 = 1 / \underline{a} = e^{j240^\circ}, \underline{a}^3 = 1, \underline{a}^4 = \underline{a} \text{ etc. Also: } \underline{a}^2 + \underline{a} + 1 = 0$$

The derivations further below are carried out with an arbitrary system of voltage phasors; the procedure applies similarly to systems comprising current phasors.

For a mathematical treatment, one defines a *complex rotation operator* \underline{a} enabling a simplified description of a component system's individual phasors. The positive, negative and zero sequences are each represented only by a single phasor here; the other two phasors can be derived from the reference phasor with the help of the complex rotation operator.

The rotation operator \underline{a} has the following value:

$$\underline{a} = -1/2 + 1/2 \sqrt{3} j = e^{j120^\circ}$$

Multiplying a phasor by \underline{a} therefore rotates the phasor by $+120^\circ$ while leaving its length unchanged.

The relationships shown next apply furthermore to \underline{a} .

$$\underline{a}^2 = 1 / \underline{a} = e^{j240^\circ}, \underline{a}^3 = 1, \underline{a}^4 = \underline{a} \text{ etc. Also: } \underline{a}^2 + \underline{a} + 1 = 0$$

Consequently, a positive sequence's phasors can be represented as shown next.

$$\underline{U}_{m1} = \underline{U}_m, \underline{U}_{m2} = \underline{a}^2 * \underline{U}_m, \underline{U}_{m3} = \underline{a} * \underline{U}_m$$

The whole positive sequence is therefore now characterized by just phasor \underline{U}_m .

Similar relationships apply to a negative sequence:

$$\underline{U}_{g1} = \underline{U}_g, \underline{U}_{g2} = \underline{a} * \underline{U}_g, \underline{U}_{g3} = \underline{a}^2 * \underline{U}_g$$

The whole negative system is therefore now characterized by \underline{U}_g .

A zero sequence can anyhow be represented adequately by a single phasor (Figure 16):

$$\underline{U}_{01} = \underline{U}_{02} = \underline{U}_{03} = \underline{U}_0$$

Analysis and synthesis require *transformation equations* for breaking down an asymmetric system into components, or performing the reverse process.

The equations for synthesis are: —

$$\underline{U}_1 = \underline{U}_m + \underline{U}_g + \underline{U}_0$$

$$\underline{U}_2 = \underline{a}^2 * \underline{U}_m + \underline{a} * \underline{U}_g + \underline{U}_0$$

$$\underline{U}_3 = \underline{a} * \underline{U}_m + \underline{a}^2 * \underline{U}_g + \underline{U}_0$$

The corresponding equations for analysis are derived from the equations above:

$$\underline{U}_m = 1/3 (\underline{U}_1 + \underline{a} * \underline{U}_2 + \underline{a}^2 * \underline{U}_3)$$

$$\underline{U}_g = 1/3 (\underline{U}_1 + \underline{a}^2 * \underline{U}_2 + \underline{a} * \underline{U}_3)$$

$$\underline{U}_0 = 1/3 (\underline{U}_1 + \underline{U}_2 + \underline{U}_3)$$

As mentioned earlier, the same relationships apply to asymmetric, three-phase current systems. Linking symmetric voltage components with symmetric current components gives rise to the concept of *positive-sequence, negative-sequence and zero-sequence impedances*: —

Positive-sequence impedance $\underline{Z}_m = \underline{U}_m / \underline{I}_m$

Negative-sequence impedance $\underline{Z}_g = \underline{U}_g / \underline{I}_g$

Zero-sequence impedance $\underline{Z}_0 = \underline{U}_0 / \underline{I}_0$

An electrical device's *positive-sequence impedance* \underline{Z}_m is the quotient between the star voltage (line-to-earth voltage) and conductor current in the case of feeding by a symmetric, positive sequence. It corresponds to the longitudinal impedance already known for lines: $\underline{Z} = R + j X$.

An electrical device's *negative-sequence impedance* \underline{Z}_g is the quotient between the star voltage and conductor current in the case of feeding by a symmetric, negative sequence. A line's negative-sequence impedance is equal to its positive-sequence impedance, because the phase sequence does not influence the amperage.

An electrical device's *zero-sequence impedance* \underline{Z}_0 is the quotient between the voltage and current if all three phases are fed by a single alternating voltage. The device's three phases are located in parallel and form the supply conductors, while a fourth conductor (neutral wire, earth, earth wire, cable jacket, cable reinforcement) serves as a common return line. This line accordingly conducts *three times the zero current*. Different currents therefore flow through the supply and return conductors. If this is considered during formulation of the mesh equation, the zero-sequence impedance is $\underline{Z}_0 = Z_m + 3 * Z_E$, where \underline{Z}_E = return conductor's impedance.

From the definition, it also follows that the zero-sequence impedance always refers to a device with a star connection. Devices with a delta connection cannot be assigned a zero-sequence impedance, due to the absence of a common return conductor.

There is no universally applicable relationship between an electrical device's zero-sequence, positive-sequence and negative-sequence impedances. A line's zero impedance, for instance, depends on the type of line (overhead line or underground cable), the line's structure (earth wire, cable jacket/reinforcement) and the conductivity of the local earth, which assumes part of the return conductor's function. Accordingly, the zero-sequence impedance is determined through measurements and estimates.

For each three-phase electrical device, it is therefore possible to specify a positive, a negative and a zero sequence. Naturally, this is also true for entire networks comprising a variety of equipment. A positive sequence's component network contains all related single-phases of equipment circuitry. The same applies to the component networks of the negative and zero sequences. The way in which these component networks are interconnected depends on the fault which has occurred.

Calculating unbalanced faults

For the sake of completeness and to permit quantitative comparisons between various types of short circuit, we will first briefly consider a three-pole (symmetric) short circuit. It can be determined by means of the following equation without a need for complex computation:

$$I_{sc\ 3\text{-pole}} = c * V_N / (\sqrt{3} * Z_{total})$$

Explanation of some of the expressions used:

c = overshoot factor. Serving as a safety margin, this factor accounts for the possibility that the feed voltage might be higher than the rated voltage shortly before occurrence of a short circuit. A value of $c = 1.1$ is normally used for planning high-voltage networks. Because a constant grid voltage is present in the laboratory, an overshoot factor of $c = 1$ can formally be employed here. Because a single phase is considered in calculations, the feed voltage here comprises a star voltage. The (single-phase) voltage on occurrence of a short circuit is also known as the initial voltage $E'' = c * V_N / \sqrt{3}$.

Z_{total} = total impedance of the short-circuited path. The short-circuit currents flowing through the three outer conductors are equal in magnitude, phase-shifted by 120° , and add up to a value of zero at the fault point. A return conductor (earth, earth wire, cable jacket) therefore need not be considered, and the short-circuited path's total impedance is the sum of the lines' and transformer's active and reactive resistances. By contrast, the supply network's internal resistance is usually negligible.

We will now consider the unbalanced fault types which might occur in a network with a solidly earthed neutral point. Other possible wirings for the neutral point are discussed later.

Demonstrated first is how to apply the method of symmetrical components when computing faulty networks. Rules for calculating short-circuits assume that the network is not under any load. The lines' working capacitances are of little influence and can be neglected.

As already mentioned, the type of short circuit occurring at the fault point serves as a basis for determining the interconnections of the component network following transformation.

The generator voltage remains symmetric even on an occurrence of unbalanced loads, the network's asymmetry being attributable solely to the respective fault. In component networks, the effective generator voltage therefore occurs only in the positive sequence, no feed signals being exhibited by the negative or zero sequence.

Single-pole short circuit

The single-pole short circuit is the most common unbalanced fault. Known as *earth-fault*, this type of short circuit is brought about by an electrical link between an outer conductor (L1) and earth.

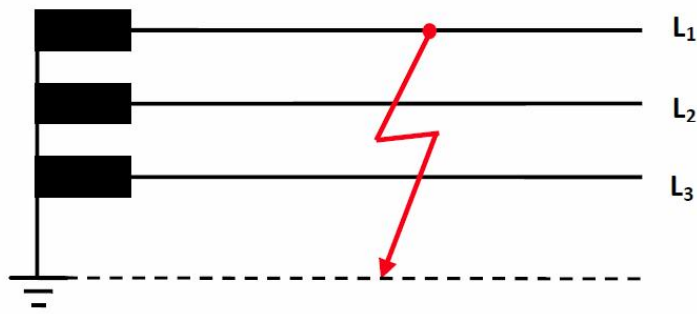

Figure 18:
Single-pole short circuit (earth fault) on outer conductor L1

The fault conditions listed next can be specified at the location of the short circuit.

$$1. \underline{I}_2 = \underline{I}_3 = 0 \text{ and } 2. \underline{U}_1 = 0$$

Transforming the fault conditions to the component level results in the following equations:

$$1. \underline{I}_m = \underline{I}_g = \underline{I}_0 = 1/3 \underline{I}_1 \text{ and } 2. \underline{U}_m + \underline{U}_g + \underline{U}_0 = \underline{U}_1 = 0$$

Consequently, this fault type can only be associated with one kind of circuit for the component network: A series circuit.

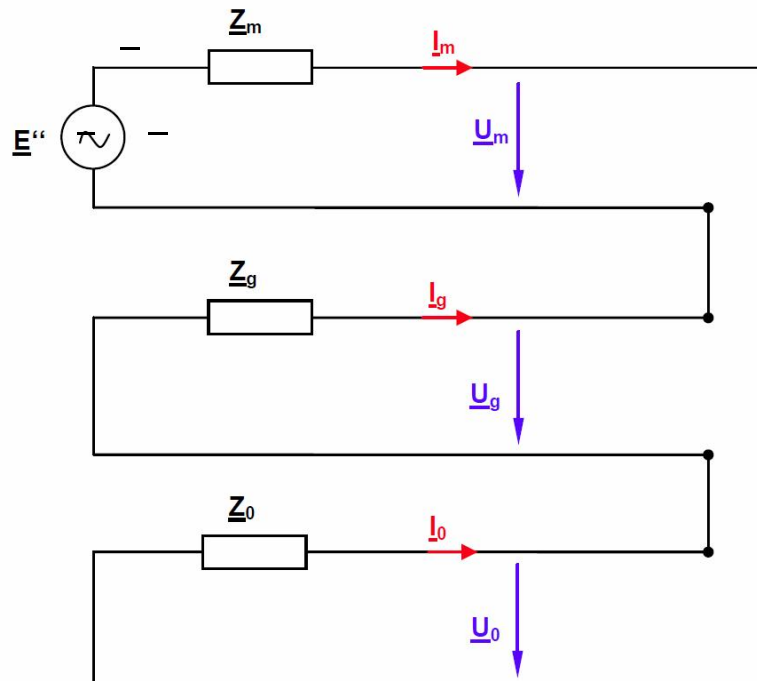

Figure 19:
Equivalent component circuit in the case of a single-pole short circuit

\underline{Z}_m , \underline{Z}_g and \underline{Z}_0 are the sums of the component impedances in the short-circuited path. E'' is the initial voltage. From the circuit above, the following relationships can be derived for the short-circuit current:

$$\underline{I}_1 = \underline{I}_{sc \text{ 1-pole}} = 3 * \underline{I}_m = 3 * E'' / (\underline{Z}_m + \underline{Z}_g + \underline{Z}_0)$$

The relationships shown next are obtained for the intact lines' voltages at the fault point:

$$\underline{U}_2 = E'' * ((\underline{a}^2 - 1) * \underline{Z}_0 + (\underline{a}^2 - \underline{a}) * \underline{Z}_g) / (\underline{Z}_m + \underline{Z}_g + \underline{Z}_0)$$

$$\underline{U}_3 = E'' * ((\underline{a} - 1) * \underline{Z}_0 + (\underline{a} - \underline{a}^2) * \underline{Z}_g) / (\underline{Z}_m + \underline{Z}_g + \underline{Z}_0)$$

The figure below provides a qualitative representation of the currents and voltages at the fault location. For the sake of simplicity, only the reactances are accounted for here.



Figure 20:

Diagrams for currents and voltages at the place of the single-pole short circuit

As previously mentioned, the derivation applies to a network with an earthed neutral point. In the event of a failure, the voltages of the intact phases do not rise. Consequently, the conductor insulation need not be designed to withstand the full line-to-line voltage. At high voltages, the resultant economic benefits of saved insulation outweigh the disadvantage of having to immediately deactivate the affected line in view of the high fault current.

Two-pole short circuit with earth fault

Assumed here is an electrical link between the outer conductors L_2 and L_3 and a zero-impedance link to earth.

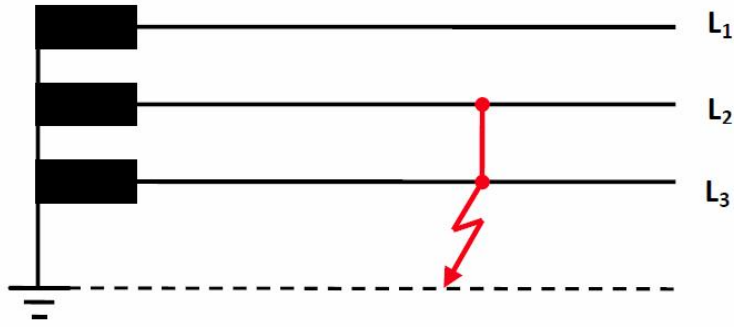

Figure 21:

Two-pole short circuit on outer conductors L₂ and L₃ with earth fault

The current and voltage values at the fault point can be determined for this short-circuit type using the same procedure as that for the single-pole short circuit. Only the procedure's results are presented next.

The fault current is: $\underline{I}_{sc\ 2\text{-pole}} = j * 3 * \underline{E}'' * \underline{Z}_g / (\underline{Z}_m * \underline{Z}_g + \underline{Z}_m * \underline{Z}_0 + \underline{Z}_0 * \underline{Z}_g)$

It is composed (geometrically) of the two partial currents as described next.

$$\underline{I}_2 = -j * \sqrt{3} * \underline{E}'' * (\underline{Z}_0 + (1 + \underline{a}^2) * \underline{Z}_g) / (\underline{Z}_m * \underline{Z}_g + \underline{Z}_m * \underline{Z}_0 + \underline{Z}_0 * \underline{Z}_g)$$

$$\underline{I}_3 = +j * \sqrt{3} * \underline{E}'' * (\underline{Z}_0 + (1 + \underline{a}) * \underline{Z}_g) / (\underline{Z}_m * \underline{Z}_g + \underline{Z}_m * \underline{Z}_0 + \underline{Z}_0 * \underline{Z}_g)$$

The following relationship applies to the intact outer conductor's voltage at the fault location:

$$\underline{U}_1 = 3 * \underline{E}'' * \underline{Z}_0 * \underline{Z}_g / (\underline{Z}_m * \underline{Z}_g + \underline{Z}_m * \underline{Z}_0 + \underline{Z}_0 * \underline{Z}_g)$$

The figure below provides a qualitative representation of the currents and voltages at the fault location. For the sake of simplicity, all active resistances in the network have been ignored.

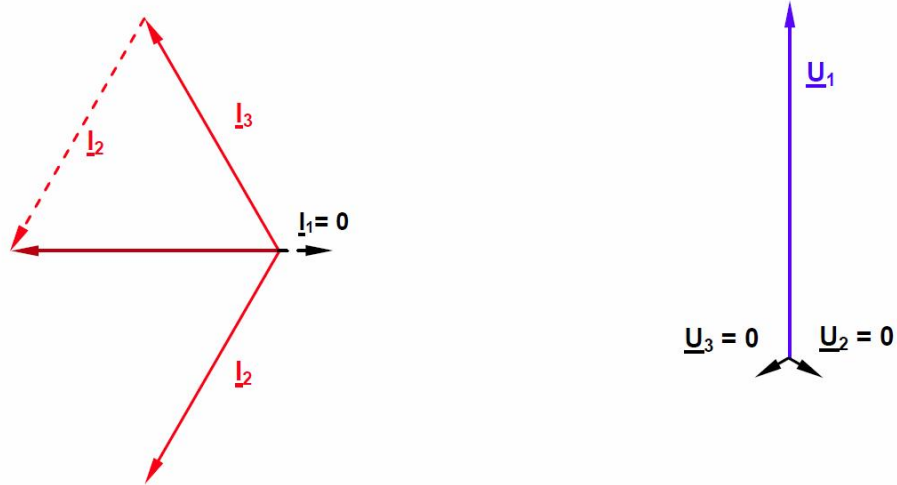

Figure 22:

Phasor diagrams for currents and voltages at the fault location in the event of a two-pole short circuit with earth fault

Two-pole short circuit without earth fault

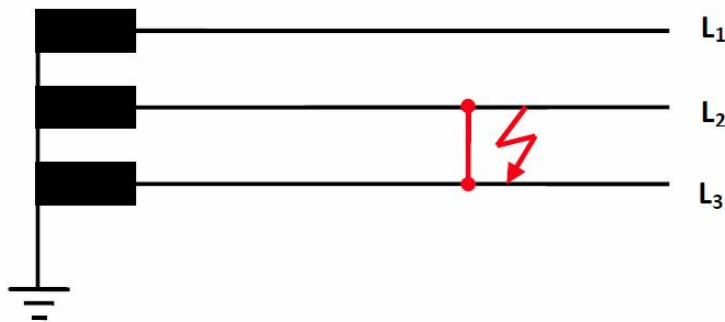

Figure 23:

Two-pole short circuit on outer conductors L_2 and L_3 without earth fault

The calculation for this fault type is simplified due to the absence of a return line via earth, and consequential absence of a zero sequence. The following relationship applies to the currents of the affected outer conductors:

$$\underline{I}_{sc\ 2-pole} = \underline{I}_2 = -\underline{I}_3 = -j \sqrt{3} E'' / (\underline{Z}_m + \underline{Z}_g)$$

In the case of transmission lines, $\underline{Z}_m = \underline{Z}_g$. Consequently, the value of a two-pole short circuit current without earth fault is $\underline{I}_{sc\ 2-pole} = \sqrt{3} * E'' / (2 * \underline{Z}_m)$ in both the affected conductors.

Because the zero sequence does not occur in the last equation, the current here can be compared easily with that of the three-pole short-circuit:

$$I_{sc\ 2\text{-pole}} / I_{sc\ 3\text{-pole}} = 1/2 * \sqrt{3} \approx 0.87.$$

The following relationships apply to the line-to-earth voltages of the three outer conductors at the fault location:

$$\underline{U}_1 = 2 * E'' * \underline{Z}_g / (\underline{Z}_m + \underline{Z}_g)$$

$$\underline{U}_2 = \underline{U}_3 = - E'' * \underline{Z}_g / (\underline{Z}_m + \underline{Z}_g)$$

Provided below is a qualitative representation of the currents and voltages at the fault location. For the sake of simplicity, all active resistances in the network are again ignored.

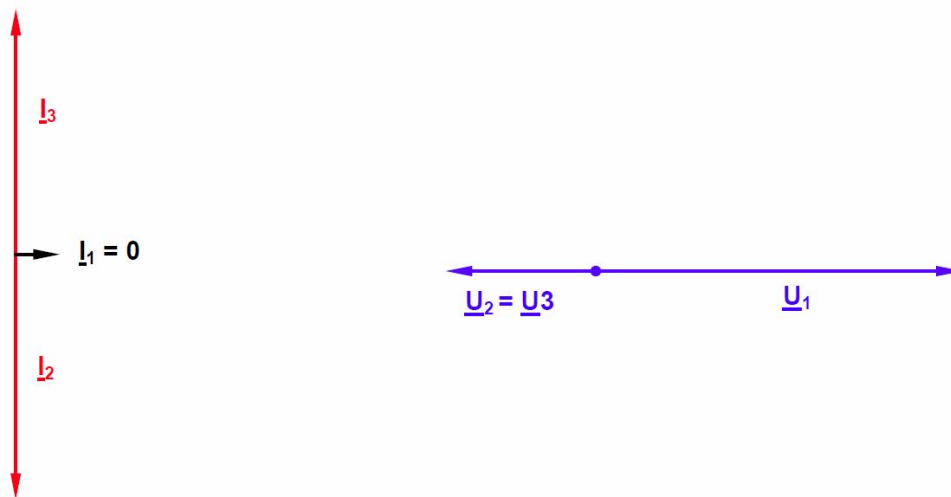

Figure 24:

Phasor diagrams for currents and voltages at the fault location in the event of a two-pole short circuit without earth fault

The relationships shown above were derived for a network with an earthed neutral point. However, other possibilities of neutral-point wiring described next are also available in dependence on the voltage level.

Network with isolated neutral point or earth fault compensation

In addition to solid neutral point earthing used for most extra-high voltage networks, it is also possible to leave the neutral point in the disconnected, i.e. isolated state. The advantage of this is a lower fault current in the event of a single-pole fault, designated *earth fault* here. The current is produced exclusively by the line-to-earth capacitances.

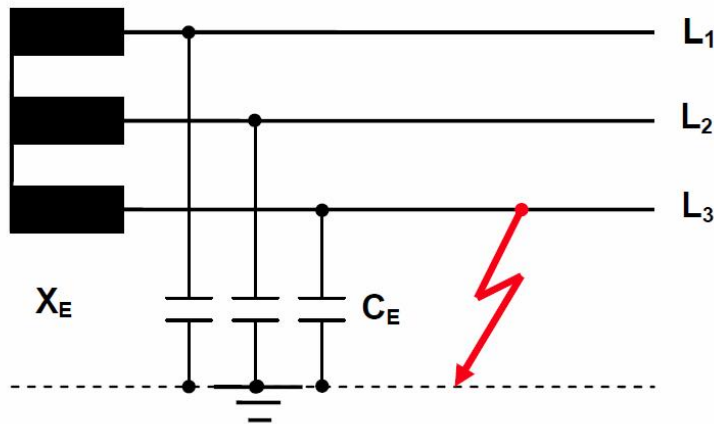

Figure 25:

Network with isolated neutral point and earth fault on conductor L3

In this case, the resultant earth fault current is: $\underline{I}_E = j\omega C_E * (\underline{V}_{13} + \underline{V}_{23})$.

If the two line-to-line voltages are assumed to have the rated level, then the *value* of the earth fault current is: $I_E = \sqrt{3} * V_N * \omega C_E$.

In addition to this purely capacitive component, the earth fault current also contains a small active component due to the line resistances and any arc resistance present at the fault location. The advantage of this neutral-point treatment is a low fault current; the disadvantage is a *voltage rise* occurring in the intact phases. As indicated in Figure 25, the voltage rises from a value of $V_N / \sqrt{3}$ to the concatenated value V_N with respect to earth. Given appropriate isolation, networks with an isolated neutral point can be operated for a while after occurrence of a single-pole fault, until the affected consumers have been appropriately switched over to alternative supply channels.

On the other hand, it is often very difficult to detect earth faults due to the low fault currents, and the voltage rise in the intact phases poses a risk of further faults elsewhere in the network (known as *double earth fault*). Consequently, this kind of neutral-point treatment is restricted to a few special cases such as small-scale, medium-voltage networks and local-service networks at power plants.

The fault current occurring in the case of an isolated neutral point is almost exclusively of a capacitive nature. Consequently, it can be compensated (quenched) by a parallel-connected inductance inside the fault-current circuit. An *earth-fault quenching coil*, also known as *Petersen coil* after its inventor, operates on this principle. Neutral-point treatment is performed via a coil which must be matched to the network's line-to-earth capacitances. Because these capacitances' total value changes during connection and disconnection, the quenching coil's inductance must also be variable. Petersen coils are therefore furnished with taps or a plunger.

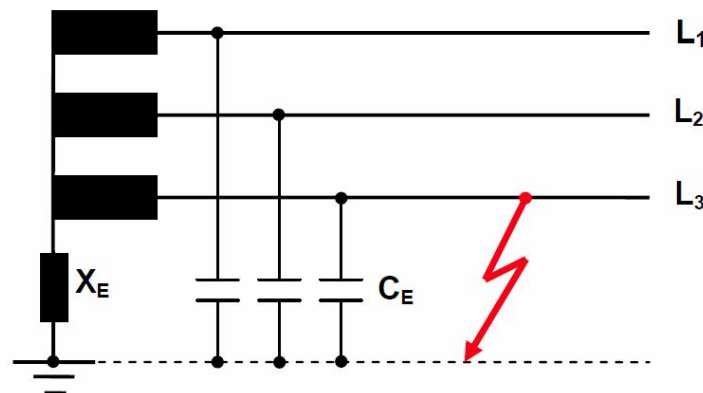

Figure 26:
Compensated network with earth fault on conductor L3

According to the method of symmetric components, the earth-fault quenching coil's inductance in the event of resonance is:

$$X_E = 1 / (3 \omega C_E)$$

The earth-fault current's active component, which cannot be compensated in this process, amounts to about 5% - 10% of the fault current and is known as *residual earth-fault current*.

If an electric arc is present at the fault location, the arc is extinguished automatically through cooling if the residual current is sufficiently low. This is the primary technical and economic benefit of the Petersen coil in transmission networks purely combining overhead lines and/or a low proportion of underground cables. On occurrence of a fault in networks purely made up of underground cables, self-extinguishing is not possible; instead the fault current is only limited.

In networks transmitting extra-high and high voltages, the residual earth-fault current would usually be too high to allow self-extinguishing. Consequently, earth-fault compensation is used primarily in medium-voltage networks, and only occasionally in high-voltage networks operating at up to 110 kV.

Transmission Systems with a Synchronous Generator

A synchronous machine can be operated both as a motor (consumer of active power) and as a generator (producer of active power). Regardless of this, the machine is also able to consume or produce reactive power. As a generator, it is therefore ideal for supplying any kind of load with electrical energy. If an asynchronous machine were to be used for this purpose, the necessary reactive power would need to be made available by means of capacitor batteries, for example. Another advantage of the synchronous machine is that it guarantees a constant frequency if driven at a constant speed. Once three-phase technology began to prevail over DC technology, this led to an emergence of separate networks incorporating synchronous generators and operating independently of each other. This was soon followed by interconnections of individual networks to form integrated systems, first at the regional level, and later at the national and even international levels. The synchronous machine has also proven to be the most useful source of energy for meeting the requirements of such joint operations. Turbo generators are turbo machines suitable for coupling to a rapidly rotating drive, e.g. a steam turbine or diesel unit. Another design, known as salient-pole machine, is more suitable for slow drives such as water or wind turbines.

The equivalent circuit diagram shown below adequately describes the operational behavior of a synchronous generator designed as a turbo machine. Like all subsequent circuit diagrams, it provides a single-phase representation.

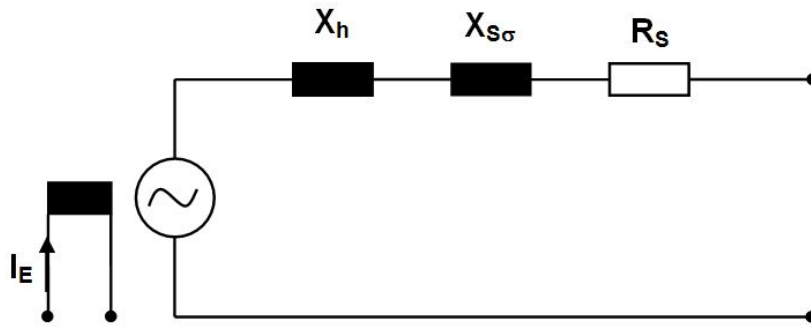

Figure 27:
Equivalent circuit diagram of a turbo generator

The stator reactance X_h and leakage reactance $X_{S\sigma}$ can be grouped into a synchronous reactance X_d . Being small compared to the synchronous reactance, the stator winding's ohmic resistance is moreover ignored in basic considerations. The excitation current flows through the rotor (pole wheel) and drives it at constant speed. At a frequency of 60 Hz and with a four-pole rotor, this speed should be 1800 rpm. The pole wheel is not shown in the next equivalent circuit diagrams. This simplifies the diagrams as follows:

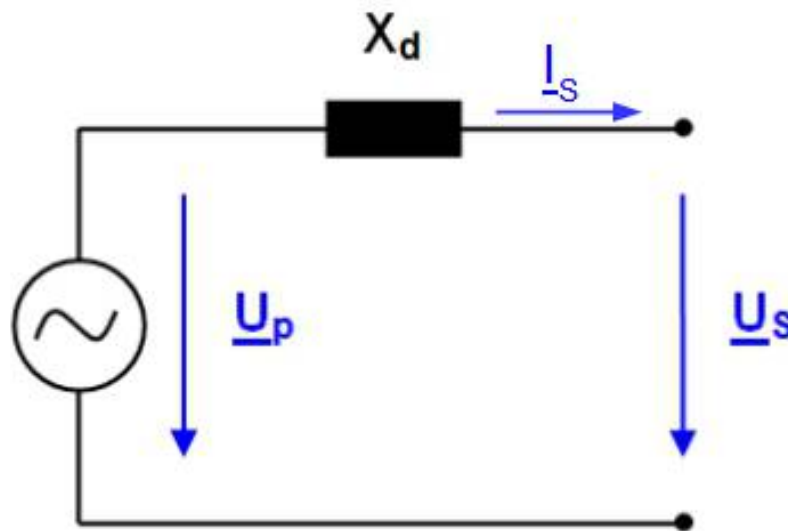

Figure 28:
Simplified equivalent circuit diagram of a turbo generator

The pole wheel produces an alternating voltage in the stator winding; designated the *pole wheel voltage* \underline{V}_p , this voltage is proportional to the excitation current. The machine voltage present across the terminals is called *stator voltage* \underline{V}_s .

The relationship between these two voltages is described by the next equation:

$$\underline{V}_p = \underline{V}_s + j X_d \cdot \underline{I}_s$$

The pole wheel voltage cannot be measured. In idle (stator current $\underline{I}_s = 0$), however, both voltages are equal.

While the generator's active power is controlled via the drive machine, the production (or consumption) of reactive power can be controlled via the generator's excitation. This is elucidated in the phasor diagrams below.

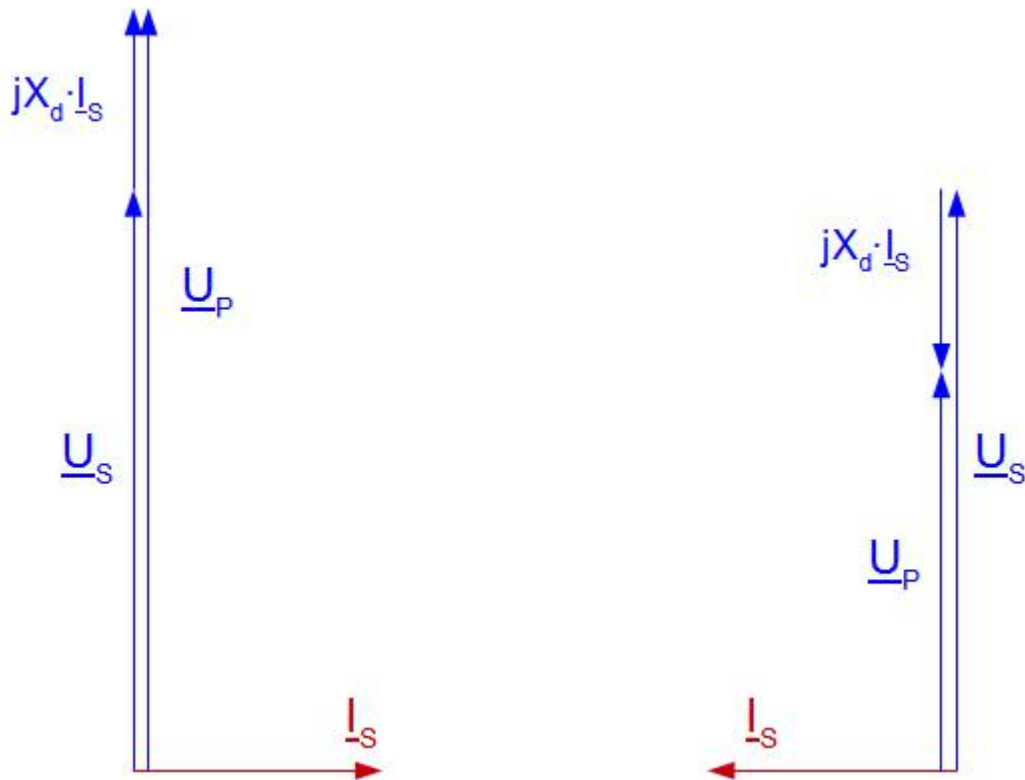

Figure 29:

Synchronous generator with inductive load (left) and capacitive load (right)

In both cases, the generator is driven mechanically such that only its friction and internal losses are covered.

In the left part of the illustration, an inductive load is connected to the generator.

The reference variables in this phasor diagram, like in all the remaining diagrams, are the voltage and current at the generator terminals. In the case of inductive loads, the current lags behind the voltage by 90° . The synchronous internal voltage is established by adding the voltage drop $j X_d \cdot \underline{I}_S$ across the synchronous reactance to the terminal voltage. To satisfy the voltage equation specified above, the synchronous internal voltage must be *higher* than the open circuit voltage. The generator is *over-excited* in this case. If the excitation is maintained at a constant level, however, the generator's terminal voltage *drops* as the inductive load increases.

In the left part of the illustration, a capacitive load is connected to the generator.

This situation is reversed here: For the voltage equation to be fulfilled now, the synchronous internal voltage must be *lower* than the open circuit voltage. In this operating mode, the generator is *under-excited*. If the excitation is maintained at a constant level, an increase in the capacitive load causes the generator's terminal voltage to *rise*.

If a resistive load is connected to the synchronous generator, the active power needed by it must be supplied as mechanical drive power to the generator. Similar to the case involving an inductive load, the terminal voltage here decreases as the load current rises, if the excitation is kept constant. This is elucidated in the next phasor diagram.

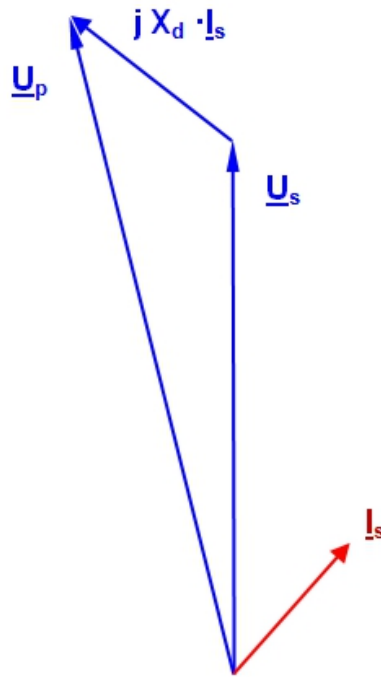

Figure 30:
Synchronous generator with a mixed resistive-inductive load

The line model used for energy transmission is represented by the familiar Π -equivalent circuit diagram treated in detail in the relevant section 1. It consists of a series inductance X_L , series resistance R_L and mutual capacitance C_B , distributed in two equal halves at the start and end of the line. As in the case of a synchronous machine, the series resistance can be ignored during basic considerations.

Interconnecting the generator, line model and load results in the circuit shown next.

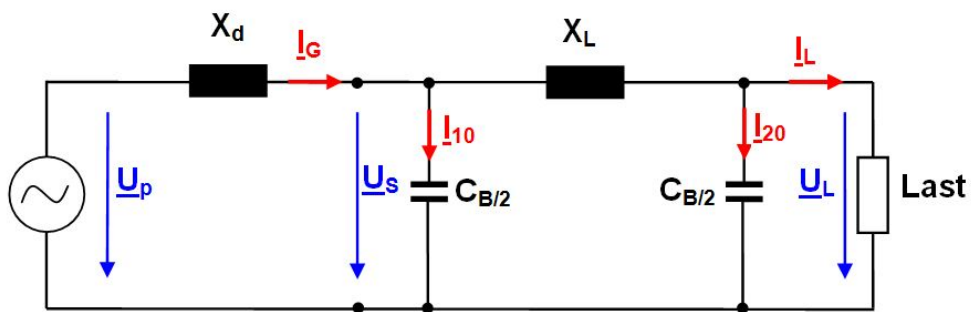

Figure 31:
Interconnection of a synchronous generator, line model and load to form an isolated system.

The system is first operated under no load. Because, the line model's inductive impedance is small compared to the mutual capacitance's impedance, it can be ignored under no load. The generator is therefore just loaded by the mutual capacitance, and the Ferranti effect familiar from the basic experiments is observed here. This behavior is explained by the next phasor diagram.

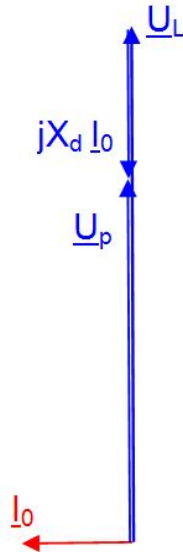

Figure 32:
Phasor diagram for an isolated system under no load

Now connect a resistor as the load. The corresponding phasor diagram is shown next.

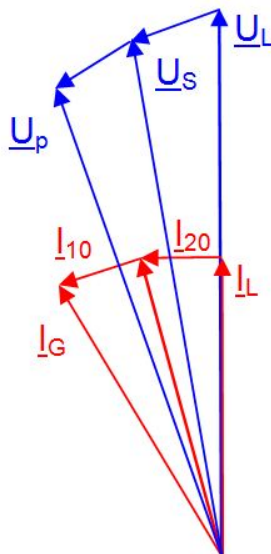

Figure 33:
Phasor diagram for an isolated system with a resistive load

Start again with the voltage and current at the end of the line. To the load current, add I_{20} flowing through the right half of the mutual capacitance. The resultant current causes a voltage drop across the line inductance. After that, it is possible to obtain the voltage V_S at the start of the line. Once V_S is known, the current I_{10} through the left half of the mutual capacitance can be determined, so that the generator current I_G is also established. From this current, the synchronous internal voltage V_p can finally be established.

The illustrated example was selected for a small load current, the line producing more reactive power than it consumes. The generator must accordingly *consume* reactive power (indicated by the fact that the generator current leads the generator voltage). Increasing the load current also increases the line's reactive power demand, which must now be met by the generator. At a particular load, whose resistance is equal to the line's *wave impedance*, the line's reactive power balance is exactly zero, i.e. the line neither produces nor consumes any such power. If a mixed-resistive-inductive load is supplied, the line's mutual capacitance becomes noticeable by slightly reducing the load's reactive power demand.

A number of conditions must be met if a synchronous machine is to be operated in parallel with the network:

First, the generator is brought to a synchronous speed so that the rotary field it produces has the same frequency as the network. Both fields must have the same direction of rotation. Also, the exciter unit should be used to set the synchronous machine's voltage so that it is equal to the network voltage. The generator may only be connected (i.e. synchronized with the network) if its voltage phasors are in the same position as those of the network. For the purpose of monitoring and fulfilling these conditions, suitable instruments and automatic facilities referred to as parallel switching devices are used.

When the synchronous generator is coupled with the network not directly, but via a transmission line, the conditions for parallel operation are to be met at the end of the line instead of the generator. After being connected in parallel to the network, the generator is able to deliver active power when its drive torque is increased. The generator can also produce or consume inductive reactive power if its excitation level is raised or lowered from the no-load state. In contrast to direct parallel operation with the network, however, the generator must then meet the connected line's reactive power demand.

Three-phase Underground Power Transmission Lines (Power Cables)

In electrical power engineering three-phase lines have to fulfill a variety of tasks:

While *power transmission networks* serve to transport high power from the large-scale power stations to the locations where power is needed most or to function as an energy exchange between members of the same power grid system. Nowadays to cover distances of 100 km (62.15 mi) and more, extremely high voltages are required to keep power transmission losses low.

On the other hand, it is the *transport network* that supplies extended urban areas and large-scale industrial plants where the high tension level being used is at a level of 110 kV. For further sub-distribution into municipal zones and industrial areas containing plants and factories as well as for rural areas there are medium voltage levels available that use voltages of 10 or 20 kV, while individual streets and districts are supplied with the lower voltage levels of 400 / 230 V or 208 / 120 V.

Two different systems are implemented to realize these tasks, namely *overhead power lines* and *underground power cables*. The generic term used for both is *power line*.

Today medium and low-voltage networks mostly come in the form of cable networks. But for high voltages, overhead power lines are still considerably more economical thanks to their simple design when compared to the complexity inherent in cables. There are still more reasons in favor of overhead power line usage, for example, their problem-free, short-term overload capacity, shorter repair times for malfunctions and last but not least their lower capacitance per unit length compared to cables.

On the other hand nature protection litigation and conservation efforts have made overhead power lines in settled areas almost impossible to implement anymore and for that reason the more expensive cable solution is often the preferred one.

For example, an overall total circuit length of around 1.7 million km (1 million mi) the high and highest voltage network segment of the cable network is just 4 %. In the medium voltage levels however the percentage of cable transmission lines is around 70 %; while in the low-voltage range it is even as high as 80 %.

Cable installations have the advantage that they are no longer visible once they have been laid and are also protected from external factors like snow storms and lightning.

The cable depth for higher voltages lies at around 6 feet and cable routes have to be kept track of and accessible for possible repair work and may not be covered over by any deep rooted trees or a dense group of bushes or trees.

Cables used for higher voltage levels have correspondingly large cross-sections and can be manufactured and transported in lengths of several hundred miles. They then have to be assembled with some effort into longer units with the aid of cable joints or junction boxes. These junction boxes have to be mechanically fixed in place with their own underground structures. In case of a cable fault (normally due to thermal, mechanical or breakage caused by aging) a new cable segment has to be deployed with the help of these junction boxes.

The transmission power of cables cannot be enhanced at will by simply selecting bigger cross-sections. Quite the contrary, limits are posed by poor thermal conductance caused by the required insulation and the surrounding earth, sometimes involving the implementation of expensive water cooling.

These problems do not arise in the case of overhead power lines since the surrounding air provides for the necessary thermal cooling and a sufficiently large cross-section can be laid when multiple conductor wires are used.

Overhead power lines for high voltages are protected against lightning strokes by means of earth or ground cable . If there is a puncture occurring to the earth conductor or the line to pole (pylon) then the arc charge arising usually extinguishes on its own for various effects (including deionizing the air) and repairs can be avoided altogether.

Finally, the difference in life expectancy for overhead lines and cables needs to be mentioned: here 40 years operating life can be assumed for cables while overhead transmission lines easily have a working life that is twice as long if not even longer.

Cables used for high-voltage power transmission can belong to any one of the essential design categories including *ground cable*, *oil cable*, *gas-pressure cable* or *plastic cable*.

Common to all cable types is a relatively complex structure combining several layers, the conductor potential needing to be lowered as far as ground potential in an extremely confined space. In this context, a formation of cavities in the insulation poses a great danger. This is caused by expansion or contraction of the insulating material under varying loads and, consequently, temperatures. Cavities have a lower permittivity than the surrounding material, thus raising the local field strength to result in partial discharges and, inevitably, cable damage.

A copper or aluminum conductor is surrounded by wire insulation. This arrangement of conductor and insulator is referred to as a *wire* in cable technology. As with overhead lines, this arrangement includes no neutral conductor, i.e. a high-voltage cable always comprises three wires.

In the case of a *three-conductor cable*, the three wires are surrounded by a common, grounded shield; in the case of a *single-conductor cable*, each wire is individually protected by a grounded shield. For applications requiring large cross-sections, single-wire variants are always used due to their advantages in terms of installation and lower transport weight.

In the case of *ground cables*, the insulating layer comprises oil-soaked paper. Applied between this layer and the conductor is an inner conductive layer which ensures homogeneity of the electric field at the conductor's surface. The wire insulation, too, is furnished with an outer conductive layer to homogenize the field. For protection against moisture and mechanical damage, the cable must furthermore be provided with an aluminum or lead sheath.

Designed like ground cables, *oil cables* in each case comprise a hollow conductor through which thin oil is pumped under pressure. This prevents a formation of cavities by alternating thermal stresses. Due to their perennial risk of contaminating ground water, ground and oil cables are now installed only in exceptional cases.

Gas-pressure cables pose no such risk, their design comprising three single-wire ground cables installed jointly in a steel conduit. This pressure-resistant conduit is filled with nitrogen maintained at about 15 bar. A distinction is made here between external and internal gas-pressure cables. In the case of external gas-pressure cables, the nitrogen atmosphere is located between the three single-wire cables and the gas tube. Gas pressure acts on the wires from outside, thus preventing a formation of cavities. In the case of internal gas-pressure cables, the nitrogen gas is located inside each wire, thereby also serving as an insulator and preventing a formation of cavities in this manner.

A *plastic cable's* insulation comprises polyvinyl chloride (PVC) in low-voltage technologies, and cross-linked polyethylene (PEX or XLPE) in applications involving medium or higher voltages. Possessing excellent dielectric and thermal properties, this plastic is therefore used even for the highest possible voltage levels now. In high-voltage applications, this type of cable is also furnished with an inner and an outer conductive layer to homogenize the field pattern. An outer shield comprising a copper braid and plastic sheath is usually applied as additional protection.

PEX cables pose no risk to ground water, nor do they absorb any water themselves. They are chemically neutral and resistant, have a low weight and can be laid with bending radii tighter than those afforded by other sorts of cable. They are the favored cable type nowadays.



Figure 34:

110kV cables being installed in a city

Due to their smaller conductor spacing and their insulation's higher dielectric constant compared with air, cables generally have a much greater capacitance than overhead lines. As a result, a cable also conducts a much higher *charging current* than an overhead line, even in the no-load state. Increasing in proportion to cable length, the charging current ultimately reaches the value of the continuous current, which the cable simply cannot handle for thermal reasons. At this *critical length*, the cable can no longer fulfil its intended purpose of transmitting active power.

Charging capacity can be compensated by parallel connections of *charge-current coils* which have to be installed in multiple instances as the cable link becomes longer. Such coils are large and expensive, and completely unfeasible for undersea cables, for instance. The only remedy here is a use of DC links which basically dispense with the problem of the charging current.

Similarly to the case of overhead lines, the equivalent circuit diagram shown below is sufficient for a consideration of a short cable route in the steady operating state. Because a single-conductor cable's wire is provided with a grounded shield in each case, however, there are no capacitances between phases, as opposed to overhead lines.

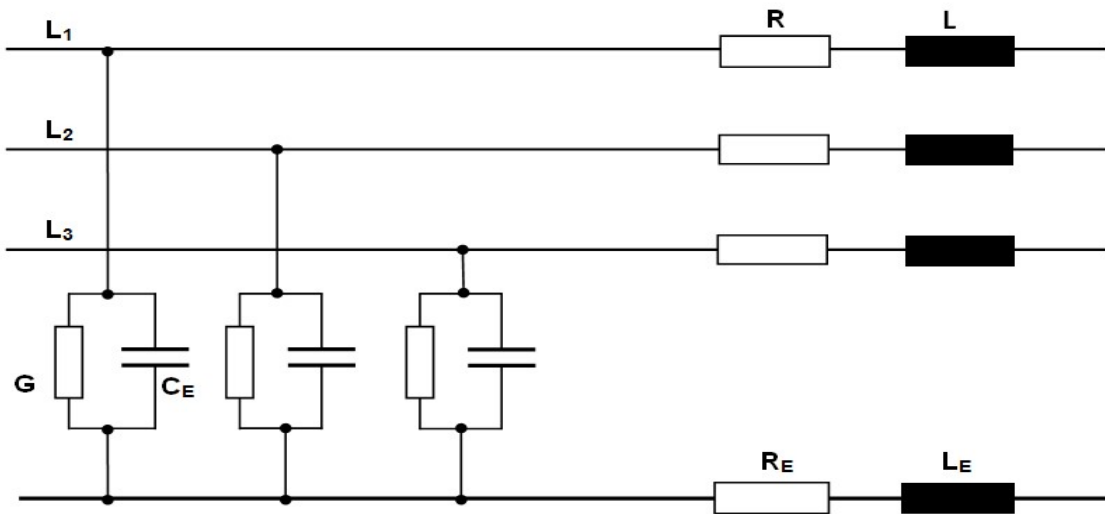

Figure 35:
Three-phase equivalent circuit diagram of a high-voltage cable (single-conductor)

Treated first of all are symmetric operating modes involving equal voltages and currents in all three phases. A return conductor is not needed here, because the three-phase currents add up to zero in the case of balanced loads.

The equivalent circuit diagram is accordingly simplified as follows:

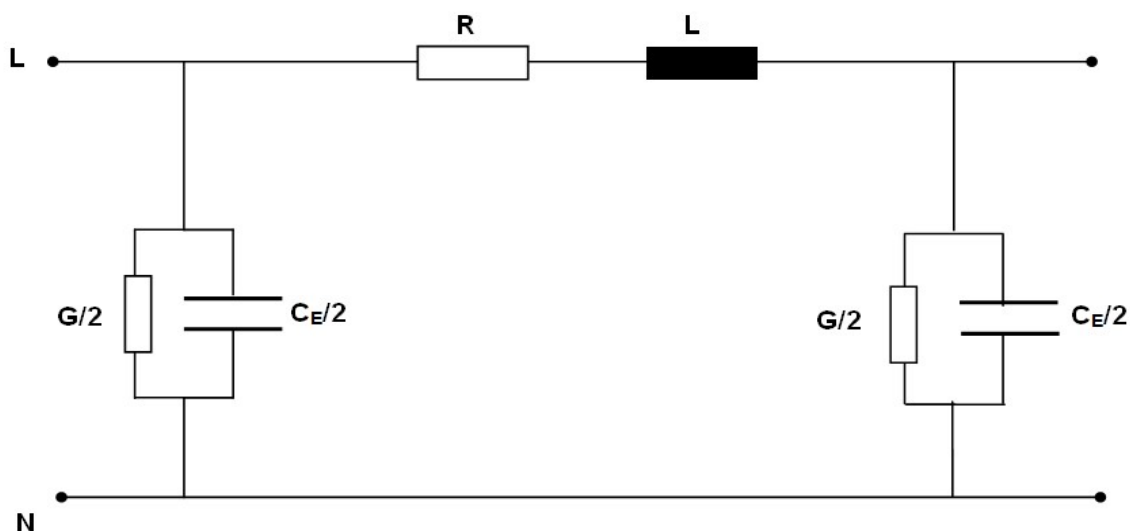

Figure 36: Single-phase equivalent circuit diagram of a high-voltage cable

As with overhead lines, the dissipation losses (represented by the conductance G) can be neglected. This is always permissible in the case of modern plastic cables with high-grade insulation.

The longitudinal resistance R is determined by the conductor material and its cross-section. Only aluminium and copper come into question as materials. Because the extra price of copper does not significantly impact a cable's total cost, copper is usually selected because of its lower resistivity.

In practical operations, the resistance has a much higher value than the one calculated from resistivity and conductor cross-section. This has three reasons: First, the cable is operated at a much higher temperature than the ambient temperature. Depending on the surrounding soil's thermal conductivity, the manufacturer approves operating temperatures of up to 90°C (194°F). Second, the *skin effect* results in higher current-heat losses. At large cable cross-sections from about 1000 mm^2 (1.55 in^2), subdivision into individual conductor segments is therefore often performed. Third, in the case of alternating currents, the induction effect always gives rise to currents in the shield as well. Depending on the type of shield grounding (at one line end, at both line ends, or with *cross-bonding* when the wire shields are cross-linked at the cable sleeves in the line path), this results in additional losses assigned mathematically to the conductor resistance.

The permissible continuous current also depends on the maximum possible conductor temperature. It is furthermore influenced by the installation method, it being possible to lay the three wires side-by-side in a single plane, or in a triangular arrangement in the cable trench. Though side-by-side installation is more efficient in terms of heat dissipation, it requires more space in the cable trench. Finally, also of importance to load capacity is whether one or more systems are installed in the trench. In any case, it is necessary to ensure good thermal conductivity of the embedment, and avoid formation of cavities.

A cable's inductance L and, consequently, its reactance X are principally lower than those of an overhead line with a similar transmission power, due to the smaller conductor spacings. Installation type plays an additional role in the case of single-conductor cables. In the case of a triangular arrangement, the wires are located closer together, thus resulting in slightly lower inductances compared with individual wires arranged side-by-side in a single plane.

The working capacitance C_B is composed of the mutual line capacitances (C_L) and the line-to-earth capacitances (C_E). As mentioned earlier, single-conductor cables do not exhibit the component C_L because of the shielding, so that the following applies here: $C_B = C_E$. This permits easy calculation of the individual capacitances according to the known relationships for a cylindrical capacitor. Of great importance here is the insulating material's relative permittivity ϵ_r , which lies in the range from 2.3 to 4.5, and equals 2.4 in the case of PEX, for instance. Also as mentioned earlier, this results basically in higher capacitance values for underground/undersea cables compared to overhead lines.

Like overhead lines, cables too can be considered as having low losses, i.e. their longitudinal resistance R is much lower than their reactance X , and their conductivity G is small compared to the conductance of their capacitance.

The equivalent circuit diagram shown next therefore suffices for a basic consideration:

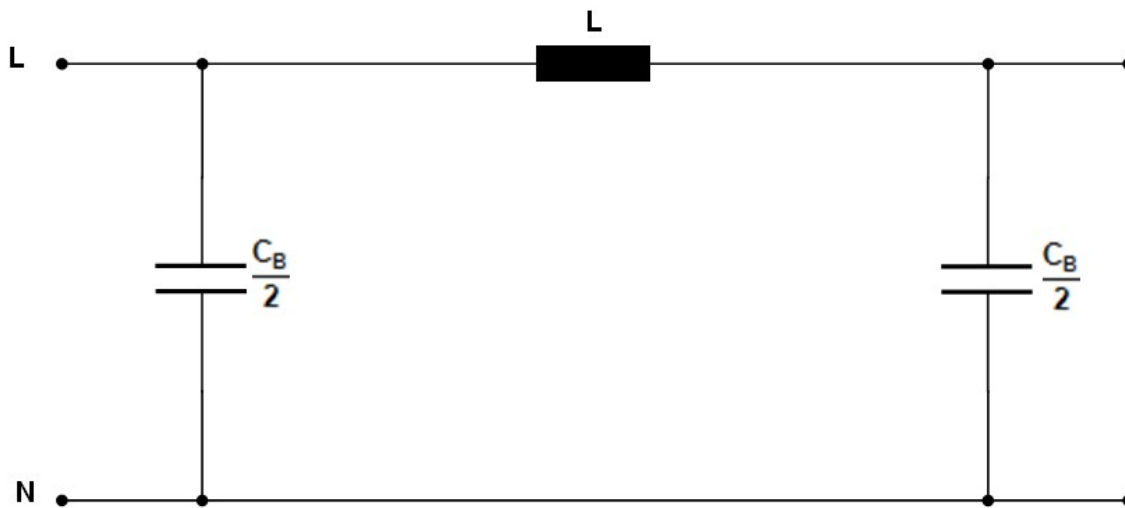

Figure 37:
Single-phase equivalent circuit diagram (simplified) of a cable

Needed in the case of unbalanced loads (such as one- or two-pole short-circuits) are the positive, negative and zero sequences according to the method of symmetrical components. The positive and negative sequences' impedances are identical in the case of underground/undersea cables as well as overhead lines.

The zero impedance is influenced decisively by the shielding's nature and grounding, as well as soil conditions. Even if these details are known in addition to the cable data, the precise values can only be determined through measurement of the installed cables.

However, the zero sequence's resistance and reactance are always higher than the positive sequence's corresponding values. Standard values lie in the range from a multiple of two to ten. In the case of a cable model, the common return conductor's values R_E and L_E must be selected appropriately to fulfill the above-mentioned condition for zero impedance in accordance with the equation $R_0 = R + 3 \cdot R_E$ or $X_0 = X + 3 \cdot X_E$.

In the case of a cable too, the *characteristic impedance* calculated as $Z_W = \sqrt{L / C_B}$ is of significance to operational behavior. Due to the much higher capacitances here, however, this impedance is always smaller than that an overhead line.

The general method of terminating a line by means of a resistive load equal to the line's characteristic impedance is known as *matching*. However, this is not possible for cables because the lower characteristic impedances here require correspondingly low load resistances. The resultant current would be far higher than the cable's permissible operating current. Unlike overhead lines, cables can therefore only be operated *below natural level*. This makes them capacitive at all times, i.e. the capacitive reactive power they produce exceeds the inductive reactive power they consume.

Like in the section three-phase overhead transmission lines, the cases involving no-load, normal operation under resistive load and symmetric short circuit can be lucidly represented by means of the following circuit diagram:

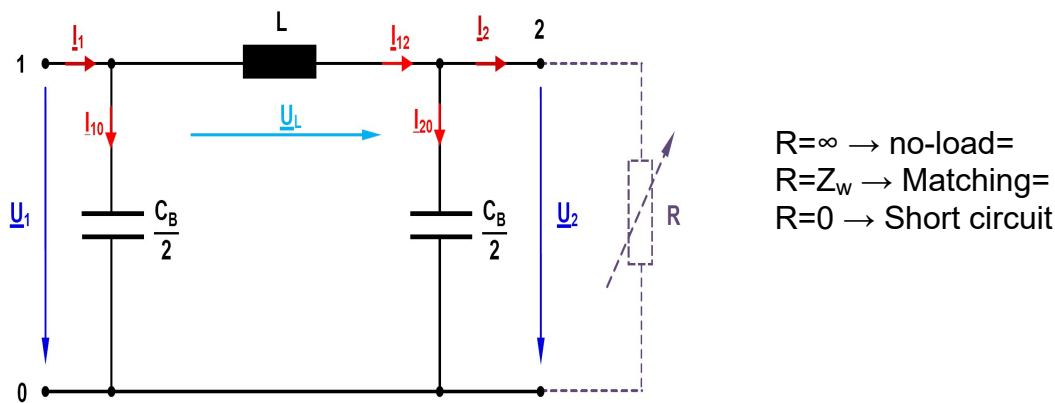

Figure 38:

Cable Operation under various types of load

Computations as part of single-phase representation make use of *star voltages*, i.e. those occurring between a phase and the neutral point (by contrast, the voltage measured between any two outer conductors is termed *line-to-line voltage* (V_{LL}) as in the case of overhead lines.

When considering a three-phase system again, the powers calculated as part of single-phase representation must now be multiplied by a factor of 3 to obtain the total power (We will employ the following designations here (complex variables are underlined):

$\underline{V}_1, \underline{V}_2$: Voltages at the cable's start and end (star voltages)

\underline{V}_L : Voltage drop across the cable

$\underline{I}_1, \underline{I}_2$: Currents at the cable's start and end

—
 $\underline{I}_{10}, \underline{I}_{20}$: Current through the shunt arm at the cable's start and end

\underline{I}_{12} : Current through the cable's longitudinal branch

-
In the *no-load state*, the terminating resistor R at the cable's end is infinitely large, so that the current $\underline{I}_2 = 0$.

-
The following current/voltage phasor diagram represents the no-load situation:

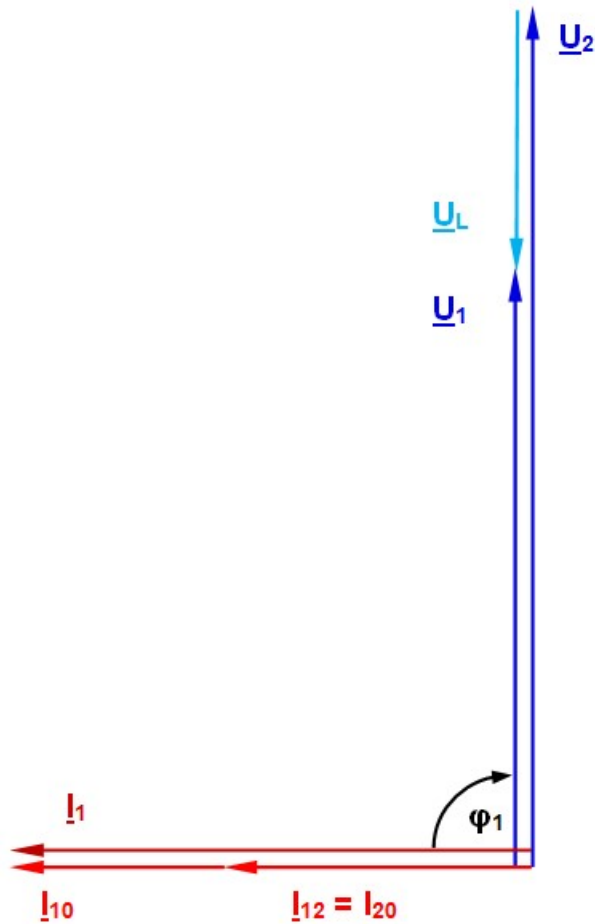

Figure 39:

Cable's current/voltage phasor diagram in the no-load state

In this operating state, the voltage at the cable's end is higher than that at the cable's start. Attributable to the working capacitance, this is known as the *Ferranti effect*. The voltage at the cable's end rises disproportionately to the cable's length, and can reach dangerously high values. This operating state is therefore avoided wherever possible in practice.

The current flowing in the no-load state is called *charging current*, the associated reactive power is termed *charging power*. As mentioned previously, cables have high working capacitances, the effects described earlier being much more significant here compared with overhead lines. In addition, the high charging capacity in the order of several Mvar per miles limits the cable route's permissible length. After that, the cable can no longer transmit any active power beyond the required charging power without causing an overload. Whereas an underground cable's charging power can be compensated by installing appropriately dimensioned charge-current coils along the line's route, undersea cables do not offer this possibility because of the notable dimensions of such facilities.

The phasor diagram below describes the situation involving a *resistive load* at the cable's end:

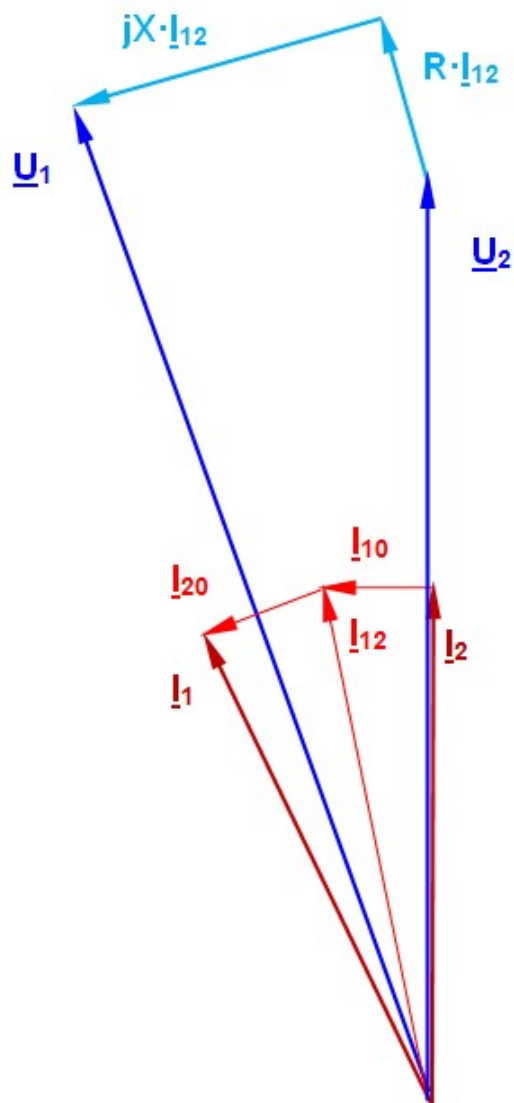

Figure 40:

Cable's current/voltage phasor diagram given termination by means of a resistive load

The load current \underline{I}_2 here is in phase with the voltage \underline{U}_2 . First, the load current must be added to the current \underline{I}_{20} divided by half the cable capacitance in order to obtain \underline{I}_{12} (the current through the cable's longitudinal branch). Once this parameter is known, both the voltage drops across the cable's active resistance and reactance can be determined. In this manner, one obtains the voltage \underline{U}_1 at the line's start, the current \underline{I}_{10} through the other half of the cable capacitance, and finally the current \underline{I}_1 at the line's start.

Illustrated next is the cable's behavior given a mixed, resistive-inductive load; the phasor diagrams are constructed as in Figure 40, so that no detailed explanation is needed again here.

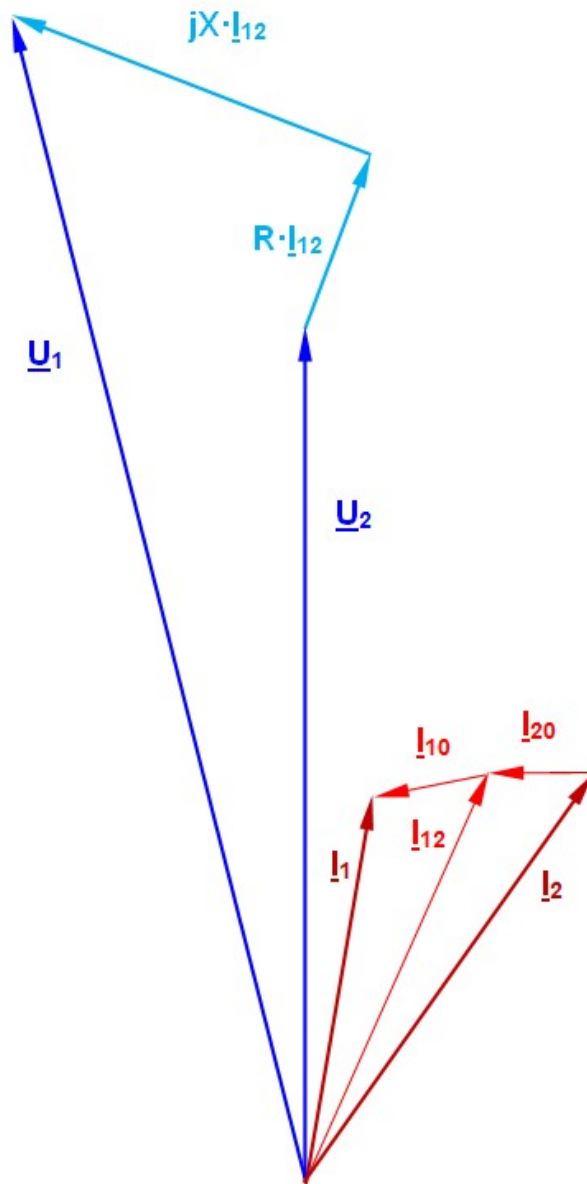

Figure 41:

Cable's current/voltage phasor diagram given termination by means of a resistive/inductive load

Just like with overhead lines, a compensation capacitance can be used to improve a resistive-inductive load's power factor. As described in detail in "Three-phase Overhead Power Transmission Lines", compensation is usually not carried out to a power factor $\cos \varphi = 1$, but only up to a value of 0.8 for economic reasons in cases of *parallel compensation*.

Series compensation is not needed due to the cable lengths which come into question here.

Occurrences of *short circuits* and *ground faults*, though less frequent than in the case of overhead lines because of the protected installation in soil, usually lead to destruction of the cable. Because repair here takes much longer compared with overhead lines, the potential economic damage caused by interrupting the power supply for large numbers of customers is correspondingly higher. Careful adjustment of the protective devices (relays) is therefore of particular importance.

Furthermore, the cable route must be protected against overload to prevent Joule effects from irreparably damaging the cable and drying the surrounding soil.

Cable routes and overhead lines have comparable transmission capacities if the same voltage levels are involved. At the high-voltage level of 110 kV, for instance, the transmission capacity is typically in the order of 100 MVA per system. This is sufficient to supply a city of about 100,000 inhabitants and the associated industrial zone.

If the transmission power needs to be doubled, for instance, it is not sufficient to simply double the conductor cross-section as in the case of an overhead line. Because of soil drying, excessive heating due to current heat losses must be avoided here. Because such losses are proportional to the square of the current, doubling the current entails quadrupling the conductor cross-section to maintain the losses at the same level.

Naturally, the transmission capacity also increases when higher voltages are used, especially because larger cross-sections are generally selected then too. As already mentioned, this also increases the transport weight of the cables / cable drums, thus requiring shorter sections with numerous couplings and consequently, uneconomical solutions in many cases involving cable routes. High-power cables are therefore found only in remarkably metropolitan areas with extremely high load densities.

In the case of overhead lines at the 380kV level, the transmission capacity is typically 1700 MVA per system. High-power cables (possibly even cooled) at this voltage level can transmit more than 2000 MVA.

Compared next finally are the most important electrical parameters of a typical overhead line and cable each operating at 110 kV and possessing similar transmission capacities:

Parameter	Overhead line	Underground/undersea cable
<i>Current-carrying capacity</i>	535 A	580 A *)
<i>Transmission power</i>	102 MVA	110 MVA
<i>Conductor material</i>	Aluminium / steel	Copper
<i>Cross-section</i>	185 mm ² (Al proportion)	300 mm ²
<i>Diameter (external)</i>	19 mm	64 mm
<i>Specific line resistance</i>	0.157 Ω / km *)	0.06 Ω / km *)
<i>Specific line inductance</i>	1.3 mH / km	0.42 mH / km **)
<i>Specific working capacitance</i>	10 nF / km	170 nF / km

*) DC resistance at 20° Celsius

**) With triangular installation and shields grounded at both ends

The data here is for a copper cable with a much larger cross-section of 1200 mm² (1.86 in²) and two possible lengths of 12.5 km (7.8 mi) and 37.5 km (23.3 mi) respectively.

This 110kV cable designated N2XS (FL) 2Y 1 x 1200 is designed for a continuous current of 1345 A and thus for a continuous power of about 250 MVA (if only one system with a parallel arrangement of single conductors is installed in the cable trench); the cable's original version has the following dimensions:

Conductor diameter:	42.8 mm (1.69 in)
Insulation layer's effective thickness:	13 mm (0.51 in)
Shield cross-section:	95 mm ² (0.18 in ²)
Cable's external diameter:	90 mm (3.54 in)
Cable's weight:	8.2 kg / m (59.3 lb / ft)

Electrical data in the case of wires installed side-by-side:

R'	0.02 Ω / km (0.32 Ω / mi)
L'	0.5 mH / km (0.8 mH / mi)
C _E '	0.32 μ F / km (0.51 μ F / mi)

In the case of representation as a Π -element, a *cable model* accordingly has the following values:

Length of 12.5 km (7.77 mi)	Length of 37.5 km (23.3 mi)
R = 0.25 Ω	R = 0.75 Ω
L = 6.25 mH	L = 18.75 mH
C _E /2 = 2 μ F	C _E /2 = 6 μ F
R _E = 0.3 Ω	R _E = 0.9 Ω
L _E = 7.5 mH	L _E = 22.5 mH

The return conductor's values here are set to 20% higher than those of the outgoing conductor.

Following are some numerical examples:

A. Mixed Load

Single-phase calculation for a cable length of 37.5 km (23.3 mi) on the basis of the phasor diagram in Figure 41 and Figure 38 as reference. The load's active power $P_2 = 300$ W and the cable's end voltage $V_{LL2} = 104$ V results in an active current:

$$I_{2 \text{ active}} = P_2 / (\sqrt{3} \cdot V_{LL2}) = 300 \text{ W} / (1.732 \cdot 104 \text{ V}) = 1.665 \text{ A};$$

the inductive load of 2 H leads to a reactive current $I_{2 \text{ reactive}} = V_{LL2} / (1.732 \cdot \omega L) = 0.294 \text{ A}$.

Consequently, the complex current at the cable's end is $\underline{I}_2 = (1.665 - j 0.294) \text{ A}$; magnitude of $I_2 = \underline{1.69} \text{ A}$.

The following applies to the load's power factor: $\tan \phi_2 = I_{2 \text{ reactive}} / I_{2 \text{ active}} = 0.18$ and $\cos \phi_2 = \underline{0.98}$.

The transverse current through half the working capacitance at the cable's end is $\underline{I}_{20} = \underline{V}_2 \cdot (j \omega C_B / 2) = j 0.113 \text{ A}$. (Star voltage $V_2 = 60.04 \text{ V}$).

The longitudinal current through the cable is $\underline{I}_{12} = \underline{I}_2 + \underline{I}_{20} = (1.665 - j 0.181) \text{ A}$.

Consequently, $\underline{V}_1 = V_2 + (R + j X) \cdot \underline{I}_{12}$. Using $R = 0.75 \Omega$ and $X = 7.06 \Omega$ (cable data) results in $\underline{V}_1 = (62.57 + j 11.61) \text{ V}$ and $\underline{V}_{LL1} = 110.2 \text{ V}$.

The transverse current through half the working capacitance at the cable's start is $\underline{I}_{10} = \underline{V}_1 \cdot (j \omega C_B / 2) = (-0.026 + j 0.141) \text{ A}$;

accordingly, the current following through the cable is $\underline{I}_1 = \underline{I}_{12} + \underline{I}_{10} = (1.639 - j 0.04) \text{ A}$; magnitude of $I_1 = \underline{1.64} \text{ A}$.

The (total) apparent power consumed by the line is $\underline{S} = 3 \cdot \underline{V}_1 \cdot \underline{I}_1^*$

I_1^* is the conjugated, complex value of I_1 . After multiplication, the active power is $P_1 = \underline{309} \text{ W}$, and the reactive power is $Q_1 = \underline{49.6} \text{ var}$.

B. Asymmetric Short Circuits

All calculations are based in a cable length of 37.5 km (23.3 mi):

1. Zero Impedance Z_0

According to Section "Three-phase Transmission Line with Earth Fault Compensation":

$\underline{Z}_0 = \underline{Z}_m + 3 \cdot \underline{Z}_E$. Using $\underline{Z}_m = (0.75 + j 7.06) \Omega$ and $\underline{Z}_E = (0.90 + j 8.48) \Omega$, one obtains $\underline{Z}_0 = \underline{(3.45 + j 32.5) \Omega}$ and $Z_0 = \underline{32.68} \Omega$.

Comparing to a real case with $V_{LL0} = 22 \text{ V}$, $I_0 = 0.37 \text{ A}$, and $Q_0 = 4.33 \text{ var}$. -

Zero impedance $Z_0 = V_0 / I_0 = (22 \text{ V} / \sqrt{3}) / I_0 = 34.3 \Omega$.

X_0 results from the equation $X_0 = Q_0 / I_0^2 = \underline{31.6 \Omega}$ so that the active component $R_0 = \sqrt{(Z_0^2 - X_0^2)} = \underline{13.3 \Omega}$.

2. Single-phase Short Circuit (Earth Fault)

Calculations are performed using the method of symmetric components and $V_{LL} = 22 \text{ V}$:

The short-circuit current is governed by: $I_{sc \text{ 1-phase}} = 3 \cdot E'' / (|\underline{Z}_m + \underline{Z}_g + \underline{Z}_0|)$

The driving voltage E'' is $22 \text{ V} / \sqrt{3}$. Furthermore, $\underline{Z}_m = \underline{Z}_g = (0.75 + j 7.07) \Omega$ and $\underline{Z}_0 = (3.45 + j 32.5) \Omega$.

Accordingly, $\underline{Z}_m + \underline{Z}_g + \underline{Z}_0 = (4.95 + j 46.64) \Omega$, the magnitude being 46.9Ω .

The magnitude of the single-phase short-circuit current therefore is $I_{sc \text{ 1-phase}} = \underline{0.81 \text{ A}}$.

A detailed calculation of the intact conductors' voltages with respect to ground according to the equations in the section three-phase transmission line with earth fault compensation have the following voltages magnitude:

$$V_2 \approx V_3 = 17.2 \text{ V}.$$

Networks's Power Flow Control

The power flow between any two nodes of a network is determined by the difference between their voltages. Differences between voltage *values* mainly influence reactive power flow, while differences between voltage *angles* decisively determine active power flow. These relationships are utilized by regulating transformers which permit adjustment not only of the transmission ratio, but also the angle between the voltages on both sides.

Any change in the load on a network always affects its voltage levels. A sharp rise in network load (like during a sudden cold snap) lowers the voltages at the affected nodes. This can be remedied through a use of adjustable transformers with a variable transmission ratio.

Besides improving voltage stability, such transformers also permit regulation of a network's active and reactive power flows, and selective power distribution in parallel transmission lines, for instance.

Two nodes designated i and k are connected by a line (overhead or underground). For simplification, we will neglect the overhead line's operating capacitance here. In high-voltage applications, the active resistance R of such lines is much smaller than their reactance X. For basic considerations, R can therefore be disregarded as well.

If i is used as the reference node, the following applies to the line-to-line voltage in notation employing polar coordinates:

$$\underline{V}_i = U_i \cdot e^{j0} \text{ and } \underline{V}_k = V_k \cdot e^{j\phi}$$

With a line reactance X, the current from node i to node k is therefore:

$$\underline{I}_{ik} = (\underline{V}_i - \underline{V}_k) / (j \cdot X) \text{ and } \underline{I}_{ik}^* = (\underline{V}_i - \underline{V}_k)^* / (-j \cdot X)$$

The asterisks here imply complex conjugate.

Accordingly, the apparent power transmitted from i to k is:

$$\underline{S}_{ik} = \underline{P}_{ik} + j \cdot \underline{Q}_{ik} = \sqrt{3} \cdot \underline{V}_i \cdot \underline{I}_{ik}^*$$

If the value from the equation above is used for the current I_{ik} , and the result represented in Cartesian notation, then:

$$\underline{S}_{ik} = \sqrt{3} \cdot [V_i^2 - V_i \cdot V_k (\cos \varphi - j \sin \varphi)] / (-j \cdot X)$$

dividing into real and imaginary components, the active power flow is:

$$\underline{P}_{ik} = -\sqrt{3} \cdot [V_i \cdot V_k \cdot \sin \varphi] / X$$

The reactive power flow is:

$$\underline{Q}_{ik} = \sqrt{3} \cdot [V_i^2 - V_i \cdot V_k \cdot \cos \varphi] / X$$

The voltages in neighboring network nodes generally differ only by a few kV. The angular differences, usually adding up to just a few degrees, are similarly small. For small angles: $\sin \varphi \sim \varphi$. At constant voltages, the transmitted active power is therefore approximately proportional to the angle between the two voltages. Furthermore, the cosines of small angles approximate 1, so that the transmitted reactive power mainly depends on the difference between the voltage values.

Example of a transmission line segment -

Considered here is a 380kV line with a length of 150 km (93.22 mi), where $X = 43.35 \Omega$ and R is negligibly small. A constant voltage $V_i = 400$ kV (reference angle 0°) should be present at node i (line start). The voltage V_k at node k (line end) is to be varied between 398 kV and 392 kV at angles from $\varphi = -2^\circ$ to -8° . The voltage at node k is therefore smaller than that at node i, and lags behind it. To be determined here are the active power flow P_{ik} and reactive power flow Q_{ik} .

The results of the approximate calculation using the relationships derived above are listed in the following table:

Voltage V_k [kV]	Angle φ [°]	Active power flow P_{ik} [MW]	Reactive power flow Q_{ik} [Mvar]
398	-2	267.3	43.2
398	-4	534.3	57.2
398	-6	800.6	88.5
398	-8	1066.0	113.3
398	-2	267.3	43.2
396	-2	266.0	81.6
394	-2	264.6	120.1
392	-2	263.3	158.6

Clearly evident are, first, the dependence of active power flow on voltage angle, and second, the dependence of reactive power flow on the difference between the voltage values. The results of calculations accounting for ohmic line resistance reveal the same trend.

Variable transformers

In the simplest case, a variable transformer is furnished on one side with several winding taps making it possible to set various transformation ratios. Here one speaks of *in-phase regulation*, only the *amount* of the secondary voltage being adjustable in this case. This type of regulation affects the values of the node voltages and, therefore, especially the *reactive power flow* in mesh-connected networks, as demonstrated earlier.

More complex circuits with a second winding on the secondary side (or use of a separate auxiliary transformer) also allow the secondary voltage's *phase angle* to be adjusted.

Transformers of this kind are therefore also known as *phase-shift transformers*. They can be used, in particular, to adjust the *active power flow* in mesh-operated networks.

If the additional voltage ΔV is with respect to the main voltage U by 90° , one speaks of *regulation in the quadrature-axis*; if the additional voltage is at other angles (typically 60°), one speaks of *phase-angled regulation*. A phase-angled controller integrates the properties of in-phase as well as quadrature-axis regulation into a single unit. In the illustration below, the primary and secondary sides are designated 1 and 2 respectively. Only the voltage phasors for phase V are shown in each case:

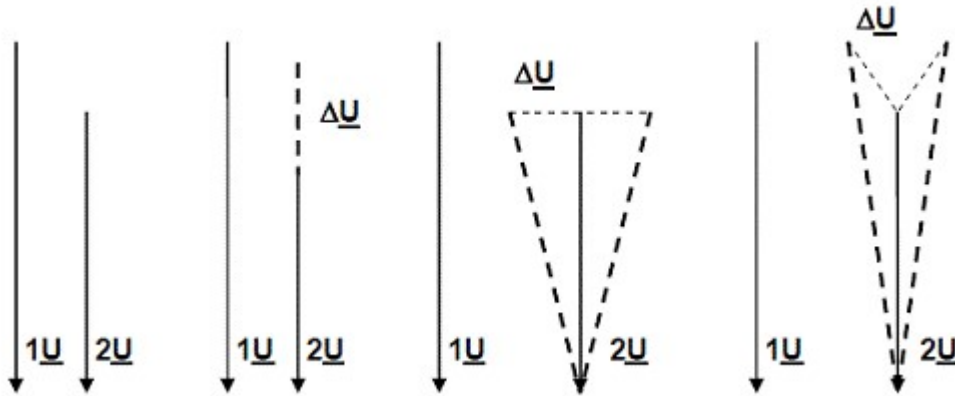

Figure 42:

Positions of the voltage phasors (regulation states: none, in-phase, quadrature and phase-angle control)

In-phase regulation is the easiest method. The different transformation ratios are realized with the help of a tap changer which ensures uninterrupted supply during switching. It is usually mounted on the transformer's high-voltage side, because smaller currents need to be switched there. Because its drive linkage must be routed out of the transformer tank, the tap changer is placed on the star-point side for reasons of insulation. A regulation range of up to $\pm 22\%$ with respect to the nominal transformation ratio is common in high and ultra-high voltage grids. This range usually comprises a total of 27 levels (nominal transformation and 13 stages respectively toward higher and lower voltages).

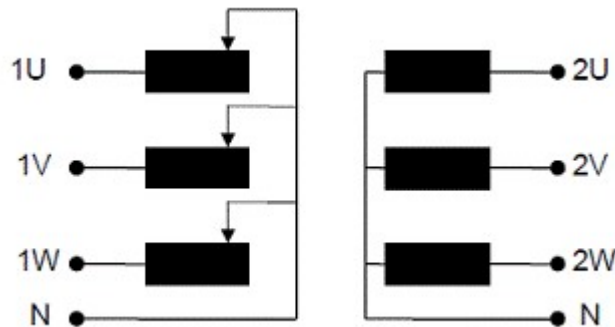

Figure 43:

Transformer with in-phase regulation

Quadrature control or regulation can only be realized with the help of an additional, auxiliary transformer. For this, the following circuit is mostly used:

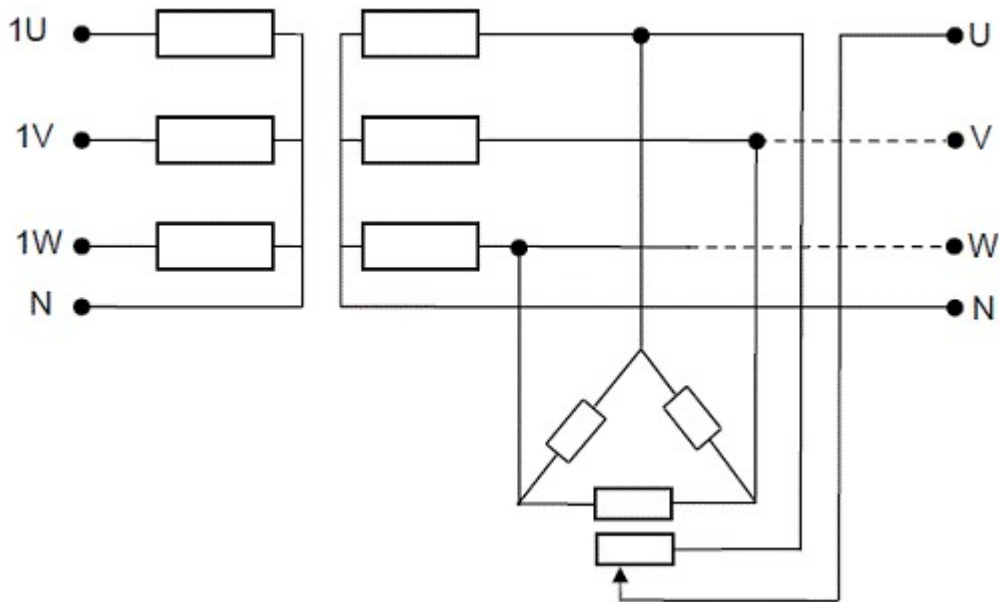

Figure 44:

Transformer with additional voltage at 90° (in quadrature control)

For the sake of clarity, the additional voltage's coupling is only drawn for phase U on the secondary side. Due to the auxiliary transformer, the output voltage now receives terminal designations U, V and W. Illustrated next are the principal options of generating a phase-shifted voltage leading or lagging by 60° . Only phase U of winding 2 and the positions of additional voltages 3V and 3W relative to voltage U2 are represented.

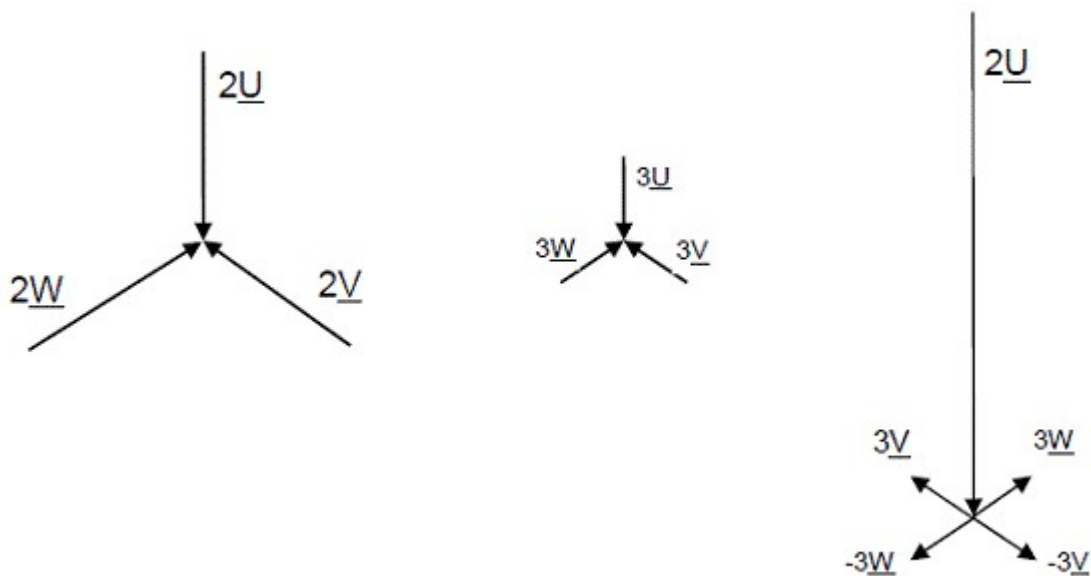

Figure 45:

Various possibilities of generating a phase-shifted voltage with the help of two secondary windings 2 and 3 (shown here only for phase U)

As the figure shows, for example, the -3V phasor leads the 2U phasor by 60° (the positive counting direction is anticlockwise). The -3V voltage is obtained by swapping the connections of series-connected windings 2 and 3. The same applies to the other phasors. All four possible combinations are presented in the experiments.

Phase angle regulation combines the in-phase and quadrature regulation capabilities in a single unit. However, the additional voltage has a fixed phase angle. The most common circuit, supplying with an additional transformer in a separate tank, results in a phase angle of 60° for the additional voltage. One possible circuit is reproduced below. For the purpose of clarity, the related circuit diagram does not illustrate the option of adjusting the voltages of the two windings 2 and 3 with the help of taps:

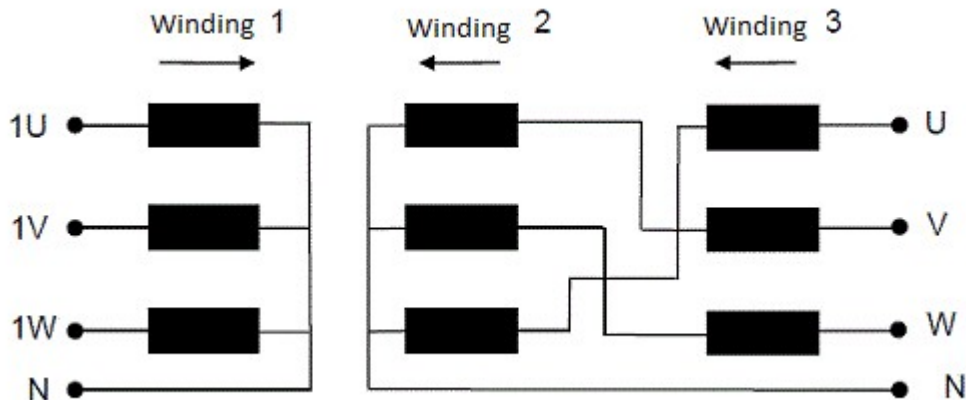

Figure 46:

Transformer with primary winding (1), main secondary winding (2) and auxiliary secondary winding (3)

The possibility of using a phase angle controller to regulate load flow can be suitably demonstrated in the following example: A power plant is to feed its power in a given ratio to two different networks, which are coupled elsewhere via an interconnecting line. From the power plant's perspective, a meshed network is therefore present with the power plant itself connected to one of this network's nodes. This situation can be reduced to the circuit shown below.

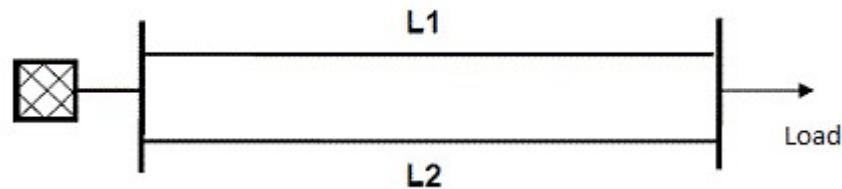

Figure 47:

Transmission system with two parallel lines

The power generation capacity is distributed on the two branches (lines or transformers) in accordance with the current division rule: Distribution is inversely proportional to the ratio between the two branch impedances. One speaks here of *natural power distribution*. If the transmission line segment consists of two lines with different cross-sections, cases may arise in which the weaker line is overloaded, although the stronger line has not yet reached its performance limit. This is also possible if the transmission line section comprises two lines of different voltage levels, as in the example below involving a 110kV line running parallel to a 380kV line.

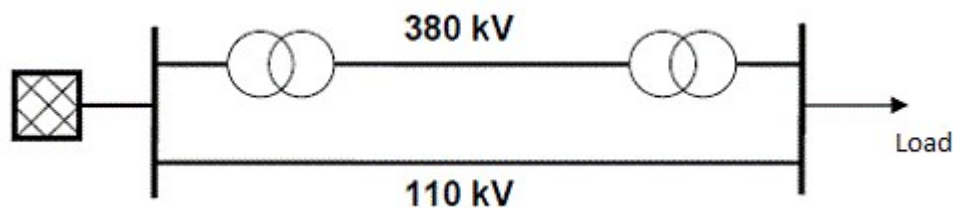

Figure 48:

Transmission system comprising two parallel lines of different voltages

Because transformers are already present in the latter case, the obvious option is to design one of them as a variable transformer in order to enforce a specific current flow which differs from the natural power distribution. A perfectly desirable side-effect here is the lower transmission losses compared with natural power distribution.

Example of a transmission line section including a variable transformer

The following data are assumed in the calculation:

L1: 380kV overhead line with $R' = 0.024 \Omega/\text{km}$ ($0.039 \Omega/\text{mi}$), $X' = 0.29 \Omega/\text{km}$ ($0.47 \Omega/\text{mi}$), $l = 50 \text{ km}$ (31.08 mi).

L2: 110kV overhead line with $R' = 0.126 \Omega/\text{km}$ ($0.203 \Omega/\text{mi}$), $X' = 0.47 \Omega/\text{km}$ ($0.76 \Omega/\text{mi}$), $l = 50 \text{ km}$ (31.08 mi). Operating capacitances are disregarded in the calculation here.

- The 380kV line has a transmission capacity (thermal power limit) of 1700 MVA. This corresponds to a current of 2.58 kA at the rated voltage.
- The following accordingly applies to the 110kV line: Transmission capacity of 135 MVA, corresponding to a current of 710 A at the rated voltage.
- Transformer: 110 kV / 380 kV, $S_N = 600$ MVA, $u_k = u_x = 12\%$. Magnetization and iron losses can be neglected here.
- Node i is connected to a fixed grid capable of supplying the required power, while load node k is to supply a power $P_k = 500$ MW, $Q_k = 200$ Mvar (inductive) at the rated voltage.
- The total impedance (with respect to 380 kV) for the upper branch is: $Z_1 = (1.2 + j 69.76) \Omega$. The result for the lower branch (also with respect to 380 kV) is: $Z_2 = (75.18 + j 232.71) \Omega$.
- The load current at node k has the value $I = (0.76 - j 0.304)$ kA. It is divided in inverse proportion to the ratio between Z_1 and Z_2 among the two branches, so that the relevant quantities here are calculated as being: $I_1 = 0.642$ kA and $I_2 = 0.183$ kA, or $I_2 = 0.632$ kA with respect to 110 kV.

In the present case, the 110kV line is therefore loaded nearly to the limit of its transmission capacity, while the load on the 380kV line amounts to just one quarter of its maximum thermal capacity. Naturally, this power distribution is therefore also not ideal in terms of transmission losses.

A transformer permitting phase angled regulation can be used to adjust the power distribution. The additional voltage u produces a loop current i in the mesh formed by both branches. Given correct polarity and phase angle position, this additional voltage increases the current in the 380kV line, and reduces the current in the 110kV line. Now the system can transmit more power without overloading the weaker line:

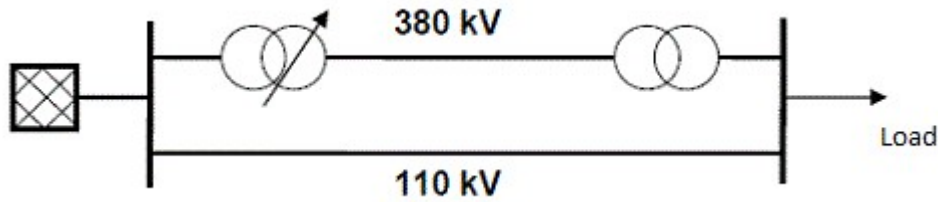

Figure 49:
Transmission system with phase angle regulation

If phase-angle regulation in the example above generates an additional voltage of 20 kV (per phase) on the 380kV side at a leading angle of 60° with respect to the main voltage, the following applies to the mesh current \underline{i} :

$$\underline{i} = \underline{u} / (\underline{Z}_1 + \underline{Z}_2) = (0.056 - j 0.017) \text{ kA}, \text{ or with respect to the 110kV level: } \underline{i} = (0.193 - j -0.059) \text{ KA}$$

This consideration disregards the (low) impedance of the auxiliary winding. The loop current increases the current through line L_1 on the 380kV side:

$$I_{1\text{new}} = \underline{I}_1 + \underline{i} = (0.635 - j 0.244) \text{ kA}, \text{ the value } I_{1\text{new}} = 0.680 \text{ kA}.$$

The current through the 110kV line (L_2) is reduced correspondingly:

$$I_{2\text{new}} = \underline{I}_2 - \underline{i} = (0.432 - j 0.034) \text{ kA}, \text{ the value } I_{2\text{new}} = 0.434 \text{ kA}.$$

The calculation shows that the current through the more heavily loaded 110kV line is reduced more than 30% using phase-angle regulation. The system comprising the two parallel lines can therefore now transmit significantly more power without overloading the 110 kV line.

To keep component requirements low, the experiments here involve operation of two parallel 380kV lines with a common transformer, whose additional voltage is connected upstream to one of the lines. The employed transformer has a delta-star circuit configuration, and a second secondary winding which can be wired as required. If the measured results are to be checked by means of a subsequent calculation, the following equivalent circuit must be analyzed for this purpose:

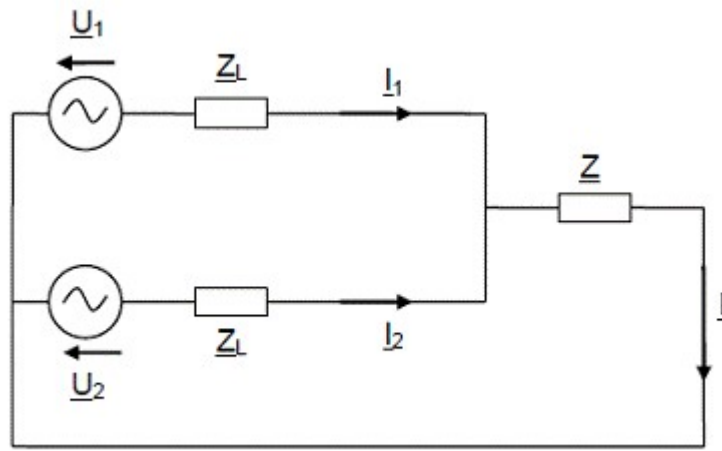

Figure 50:

Equivalent circuit for two parallel lines supplied with different voltages

The two lines are identical and initially represented only by their impedance Z_L . \underline{V}_1 is the voltage present on line 1 downstream from the phase-angle controller. \underline{V}_2 is the unregulated voltage on line 2. \underline{I} is the current flowing through the load \underline{Z} . The following equations apply:

$$\underline{V}_1 = \underline{Z}_L \cdot \underline{I}_1 + \underline{Z} \cdot \underline{I}$$

$$\underline{V}_2 = \underline{Z}_L \cdot \underline{I}_2 + \underline{Z} \cdot \underline{I}$$

$$\underline{I}_1 + \underline{I}_2 = \underline{I}$$

Resolving these equations results in:

$$\underline{I} = (\underline{V}_1 + \underline{V}_2) / (\underline{Z}_L + 2 \underline{Z}) \text{ and}$$

$$\underline{I}_1 = (\underline{V}_1 \cdot \underline{Z}_L + \underline{V}_1 \cdot \underline{Z} - \underline{V}_2 \cdot \underline{Z}) / (\underline{Z}_L^2 + 2 \underline{Z} \cdot \underline{Z}_L)$$

$$\underline{I}_2 = (\underline{V}_2 \cdot \underline{Z}_L + \underline{V}_2 \cdot \underline{Z} - \underline{V}_1 \cdot \underline{Z}) / (\underline{Z}_L^2 + 2 \underline{Z} \cdot \underline{Z}_L)$$

For exact modelling, both lines' operating capacitances must be considered too. This results in additional quadrature-axis component currents at each of the two lines' start and end.

Voltage Regulation with a Three-phase Variable Transformer

Electrical energy in extensive networks can be transferred economically only if multiple voltage levels are employed for this purpose. Depending on generator capacity, voltages ranging to 27 kV arise in the domain of power plants, whereas transmission over long distances, including supply of large cities, takes place at 220 or 380 kV.

Distribution networks supplying medium-sized cities and industrial facilities usually do so with 110 kV, while rural areas and commercial enterprises generally receive 10 or 20 kV. In addition, 400/230 V are available for local networks (households and small consumers).

The different voltage levels are interlinked by means of transformers. Instead of possessing a fixed ratio, these can usually be adapted to the prevailing load situation via coil taps. This reduces voltage dips in the grid to ensure that customers are supplied with a largely constant voltage.

The individual windings of three-phase transformers can be configured in a delta (identifier D) or star (identifier Y) circuit. Whereas in the case of a delta circuit, the full, external line-to-line voltage is present across a winding phase, in the case of a star circuit a winding phase is loaded only with the star voltage ($V_{LL} / \sqrt{3}$). Though this reduces insulation costs, it also requires larger copper cross-sections because of the higher currents. Star connections are used preferentially for high and extra-high voltages.

Transformers with galvanically isolated windings for both voltage levels are known as separate-winding transformers. Another configuration option comprises an autotransformer, in whose case the high- and low-voltage windings exhibit a common part called the parallel winding. Another winding part, associated only with the high-voltage side, is called the series winding. Both partial windings are connected in series and inductively coupled. The autotransformer is identical to that of an inductive voltage divider, though able to step voltages not only down but also up. Autotransformers are identified additionally by the letter 'a'.

The following overview shows the voltage bands commonly used in individual grid levels, and the ranges over which the transformation ratios can usually be adjusted. To minimize transmission losses, it is necessary to stay, to the extent possible, inside the upper voltage bandwidths because the currents flowing in this case are lower.

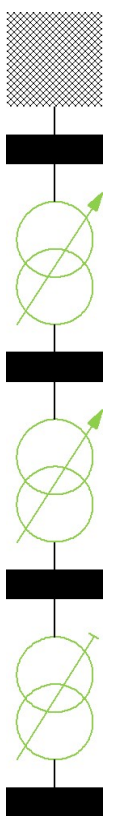

	Voltage level	Voltage range	Adjustment range
	380/220 kV	$\pm 10\%$	
			$\pm 22\%$
	110 kV	$\pm 10\%$	
			$\pm 16\%$
	20 kV	$\pm 10\%$	
			$\pm 4\%$
	0.4 kV	$\pm 10\%$	

Figure 51:

Example of common voltage bands and adjustment ranges of the corresponding transformers

Elaborate circuits referred to as *tap changers* are needed to realize variable transformation ratios. They must be constructed to prevent interruptions in current flow during switchover.

Tap changers are usually mounted on the high-voltage side to reduce the currents flowing through them. Because the linkage rods needed to operate tap changers must be routed out of the transformer tank, the changers are situated on the star-point side to facilitate insulation. Control ranges attaining $\pm 22\%$ with respect to the rated transformation ratio are common in grids conducting high and extra-high voltages. They are usually designed to comprise a total of 27 levels (rated transformation, 13 stages of ascending voltage, 13 stages of descending voltage). The tap changers are generally remote-controlled via a motor.

For reasons of economy, substation transformers were earlier furnished with simple changeover mechanisms whose actuation was permissible only in the de-energized state. Due to a rapid proliferation of photovoltaic electricity in low-voltage grids, many regions experience large voltage fluctuations during changes in solar irradiation and load. The industry is therefore also developing voltage regulators for substation transformers. These usually have an electronic design for cost reasons.

Changing the transformation ratio influences only the magnitude of the secondary voltage, not its phase position. Control transformers of the kind described are therefore only capable of longitudinal control or direct voltage adjustment.

Also in existence are other variants (e.g. in the form of auxiliary transformers) which supply an auxiliary secondary voltage variable in terms of magnitude and phase. If the auxiliary and main voltages together form an angle of $\pm 90^\circ$, one speaks of *transverse control*; in the case of any other angle (typically $\pm 60^\circ$) one speaks of *oblique control*. Transverse and oblique control are also known as *indirect voltage adjustment*. Transformers with indirect adjustment entail elaborate, expensive design, and often need a second tank for the control winding.

As demonstrated in oblique control transformers, longitudinal control can be used to adjust *reactive power flow* in a mesh network, whereas transverse or oblique control and consequent variations in phase angle can be used to adjust *active power flow*. In mesh networks, this makes it possible to enforce optimization of active power flow, thus reducing transmission losses compared to natural power distribution in accordance with the line impedances. This optimizes utilization of existent line cross-sections and avoids ring currents in meshes.

Experiments

Three-phase Overhead Power Transmission Line

In these experiments are explored the three operating states of no-load, matching and short-circuit for the two line lengths of 150 and 300 km (93.22 and 186.45 mi). Two three-phase wattmeters can be used to simultaneously measure all voltages and currents as well as active, reactive and apparent powers at both line's star and end of transmission lines. The feed transformer's voltage at the start of the line is to be increased in *steps* to the specified value in each case. **In this process, make sure that the maximum permissible values of voltage (400 V between two outer conductors phases) and current (2.5 A during short circuit) are not exceeded anywhere.**

Procedure

Set up the circuit as illustrated next and adjust the resistive load to its maximum value.

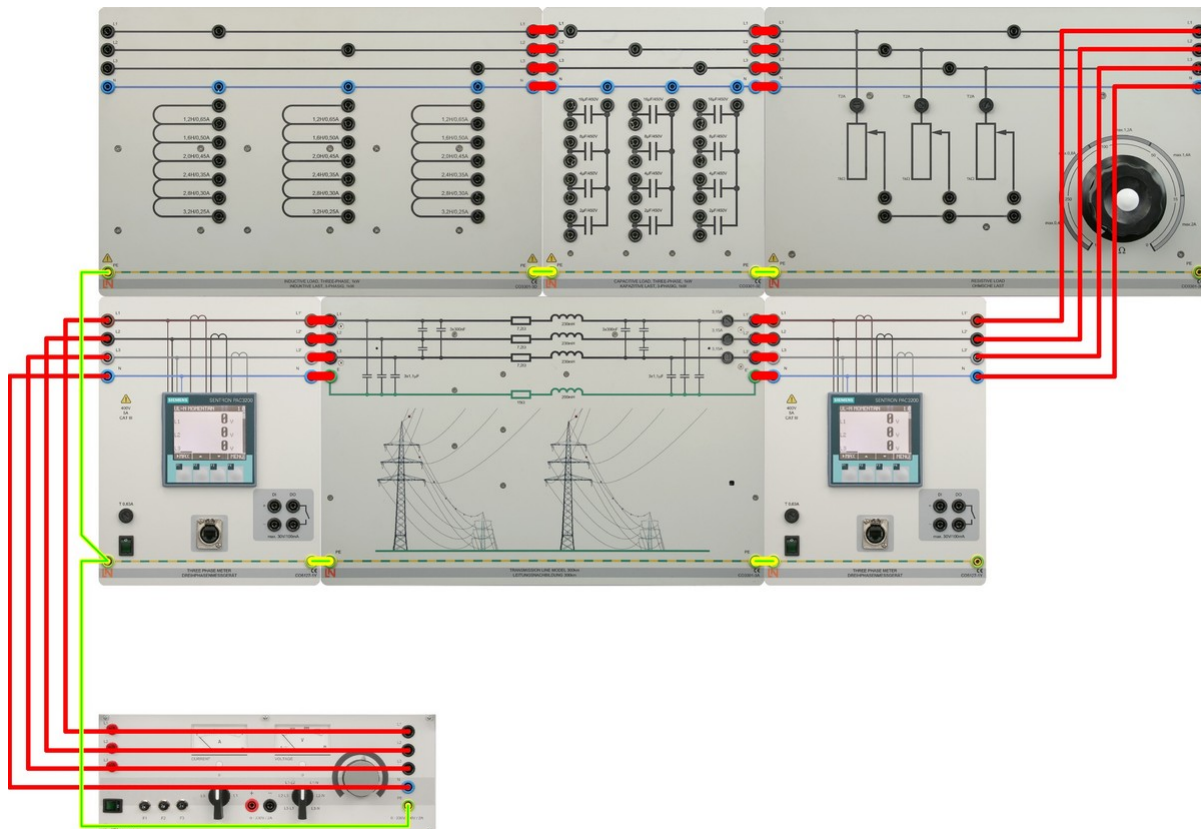

Figure 52:

Experiment circuit for measurements in the no-load, matching and short-circuit modes

Case 1: No-load

Use circuit of Figure 52 with no resistive load to study operating response under no-load.

Line length of 150 km (93.22 mi):

1. Turn on the three-phase power source and set the voltage to the nominal value $V_{LL} = 380$ V at the beginning of the line.
2. Measure and record the variables indicated in the Table 1. The outer conductors are designated L_1 , L_2 and L_3 , the neutral conductor N. The powers (W, VAR, and VA) always accounts for three-phase values, i.e. total power levels.
3. Turn off the three-phase power supply.

Line length of 300 km (186.45 mi):

1. Turn on the three-phase power source and set the voltage to the nominal value $V_{LL} = 380$ V at the beginning of the line.
2. Measure and record the variables indicated in the Table 1. The outer conductors are designated L_1 , L_2 and L_3 , the neutral conductor N. The powers (W, VAR, and VA) always accounts for three-phase values, i.e. total power levels.
3. Turn off the three-phase power supply.

	Line's Start										Line's End			
	V_{LN1}	V_{LN2}	V_{LN3}	V_{LL12}	I_{L1}	I_{L2}	I_{L3}	W	VAR	V_{LN1}	V_{LN2}	V_{LN3}	V_{LL12}	
150 km (93.22mi)														
300 km (186.45 mi)														

Table 1:

Three-phase Power Transmission Line @ No- Load Configuration

Case 2: Resistive and Matching Load

Use circuit of Figure 53 with a resistive load to study operating response under load and matching conditions.

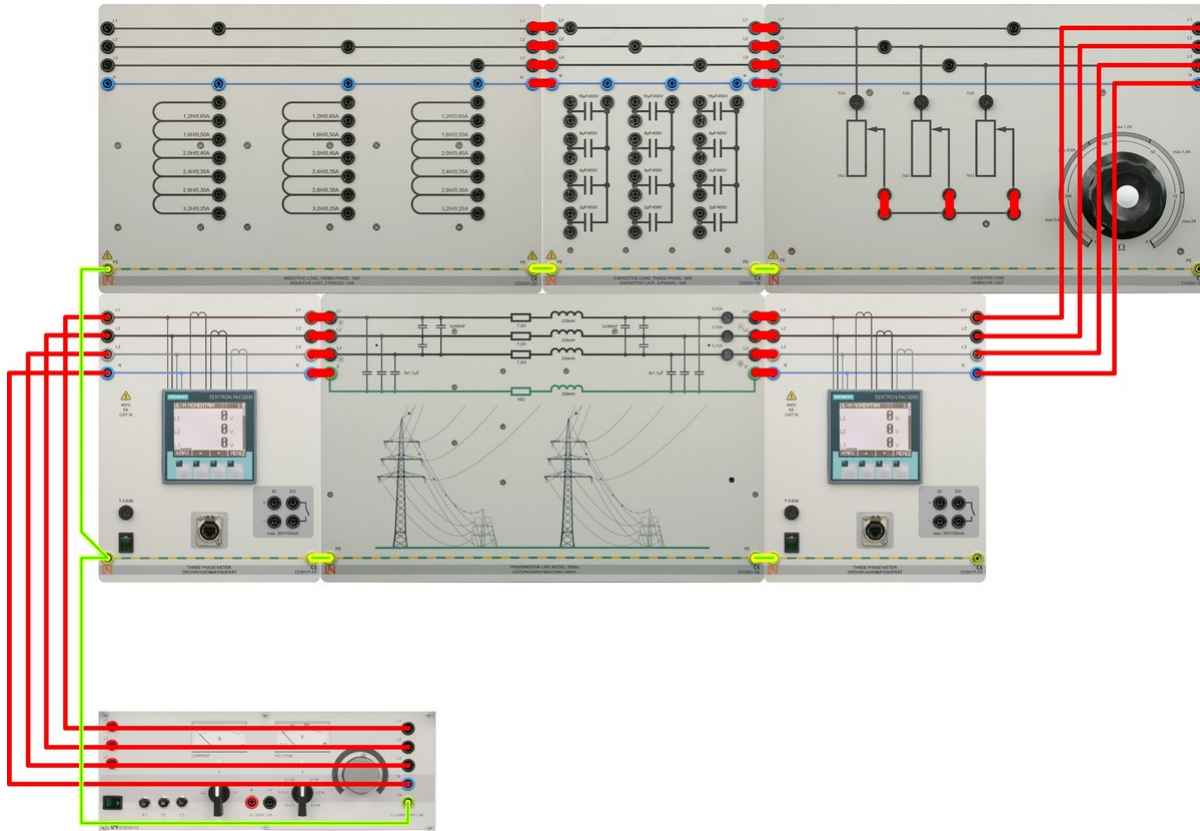

Figure 53:

Experiment circuit for measurements with purely resistive loads

Line length of 150 km (93.22 mi) with resistive load:

1. Make sure the resistive load is at its maximum value adjusting it by its knob.
2. Turn on the three-phase power source and set the voltage to the nominal value $V_{LL} = 380$ V at the beginning of the line and maintained at this value through readjustment wherever necessary.
3. Decrease the resistive load from its maximum value until you reach a total active power of 300 W measured at the end of the transmission line.
4. Measure and record the variables indicated in the Table 2.
5. Repeat steps 2 to 4 for total active powers of 400, 500, 600, and 700 W at the end of the transmission line.
6. Turn off the three-phase power supply.

Line length of 300 km (186.45 mi) with resistive load:

1. Make sure the resistive load is at its maximum value adjusting it by its knob.
2. Turn on the three-phase power source and set the voltage to the nominal value $V_{LL} = 380$ V at the beginning of the line and maintained at this value through readjustment wherever necessary.
3. Decrease the resistive load from its maximum value until you reach a total active power of 300 W measured at the end of the transmission line.
4. Measure and record the variables indicated in the Table 2.
5. Repeat steps 2 to 4 for total active powers of 400, 500, 600, and 700 W at the end of the transmission line.
6. Turn off the three-phase power supply.

Line length of 150 km (93.22 mi) with matching load:

1. Make sure the resistive load is at its maximum value adjusting it by its knob.
2. Turn on the three-phase power source and set the voltage to the nominal value $V_{LL} = 380$ V at the beginning of the line and maintained at this value through readjustment wherever necessary.
3. Decrease the resistive load from its maximum value until you reach a minimum total supplied reactive power (theoretically zero) measured at the start of the transmission line.
4. Measure and record the variables indicated in the Table 3.
5. Turn off the three-phase power supply.

Line length of 300 km (186.45 mi) with matching load:

1. Make sure the resistive load is at its maximum value adjusting it by its knob.
 2. Turn on the three-phase power source and set the voltage to the nominal value $V_{LL} = 380$ V at the beginning of the line and maintained at this value through readjustment wherever necessary.
 3. Decrease the resistive load from its maximum value until you reach a minimum total supplied reactive power (theoretically zero) measured at the start of the transmission line.
 4. Measure and record the variables indicated in the Table 3.
 5. Turn off the three-phase power supply.
-

150 km (93.22 mi)	Line's Start			Line's End		300 km (186.45 mi)	Line's Start			Line's End	
Total Act Power (W)	I_{L1}	W	VAR	I_{L1}	V_{LL12}	Total Act Power (W)	I_{L1}	W	VAR	I_{L1}	V_{LL12}
300						300					
400						400					
500						500					
600						600					
700						700					

Table 2:

Three-phase Power Transmission Line @ Resistive Load Configuration

150 km (93.22 mi)						300 km (186.45 mi)					
Total Act Power (W)	Line's Start			Line's End		Total Act Power (W)	Line's Start			Line's End	
@ Line's end	I_{L1}	W	VAR	I_{L1}	V_{LL12}	@ Line's end	I_{L1}	W	VAR	I_{L1}	V_{LL12}

Table 3:

Three-phase Power Transmission Line @ Matching Load Configuration

Case 3: Three Pole Symmetric Short Circuit

Use circuit of Figure 53 without a resistive load to study operating response under three pole symmetric short circuit conditions. The transmission line can be considered as a model of a 110-kV line possessing the same line constants for R, X and C_B as a 380-kV line. Even with these values, the line model remains realistic. Because of the high current in the short-circuited state, the experiment should be carried out quickly at a reduced supply voltage. The currents are measured only in the steady state. The initial values occurring on a short circuit of relatively short lines in meshed networks with multiple feeds can be much higher.

Line length of 150 km (93.22 mi) with short circuit:

1. Make sure the resistive load is disconnected from circuit.
2. Connect the three outer conductors to each other as well as the return conductor (short circuit).
3. Turn on the three-phase power source and set the voltage to the nominal value $V_{LL} = 110$ V at the beginning of the line.
4. Measure and record the variables indicated in the Table 4.
5. Turn off the three-phase power supply.

Line length of 300 km (186.45 mi) with short circuit:

1. Make sure the resistive load is disconnected from circuit.
2. Connect the three outer conductors to each other as well as the return conductor (short circuit).
3. Turn on the three-phase power source and set the voltage to the nominal value $V_{LL} = 110$ V at the beginning of the line.
4. Measure and record the variables indicated in the Table 4.
5. Turn off the three-phase power supply.

150 km (93.22 mi)				300 km (186.45 mi)					
Line's Start			Line's End	Line's Start				Line's End	
I_{L1}	W	VAR	V_{LL12}	I_{L1}	I_{L1}	W	VAR	V_{LL12}	I_{L1}

Table 4:

Three-phase Power Transmission Line @ Short Circuit Configuration

Case 4: Mixed Loads

The most important case in practice is a supply for mixed resistive-inductive loads. Investigated beforehand, however, is the line response in the case of purely capacitive and inductive loads. Besides purely resistive loads (lighting, process heat), operations in a real power network also involve numerous loads of a resistive-inductive nature (transformers, electric motors). The overall power factor $\cos \phi$ in this case usually ranges between 0.8 and 0.9. These load cases are accordingly given due consideration below.

Line length of 150 km (93.22 mi) with purely capacitive loads:

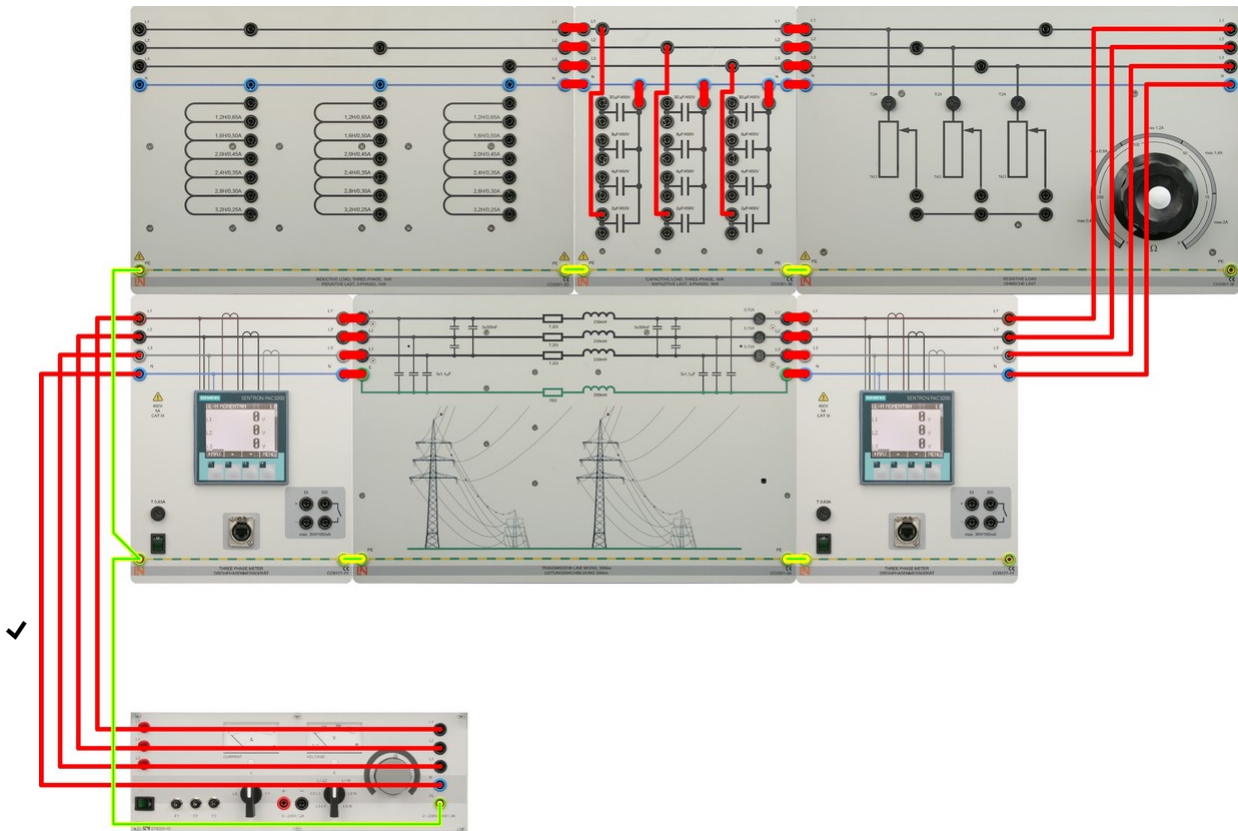

Figure 54:

Experiment circuit for measurements with purely capacitive loads

1. Assemble the circuit as shown in Figure 54.
2. Connect capacitors of $2 \mu\text{F}$ in star configuration (Y).
3. Turn on the three-phase power source and set the voltage to the nominal value $V_{LL} = 340 \text{ V}$ at the beginning of the line and maintained at this value through readjustment wherever necessary.
4. Measure and record the variables indicated in Table 5. The powers (W, VAR, and VA) always accounts for three-phase values, i.e. total power levels.
5. Turn off the three-phase power supply.
6. Repeat steps 2 to 4 for capacitor values of $4 \mu\text{F}$, $6 \mu\text{F}$, $8 \mu\text{F}$, $10 \mu\text{F}$, and $12 \mu\text{F}$.
Readjusting the power supply to its nominal value wherever necessary.

150 km (93.22 mi)						
Cap	Line's Start			Line's End		
3 ϕ Y	I_{L1}	W	VAR	I_{L1}	V_{LL12}	VAR
2 μ F						
4 μ F						
6 μ F						
8 μ F						
10 μ F						
12 μ F						

Table 5:

Three-phase Power Transmission Line @ Capacitive Load Configuration

Line length of 150 km (93.22 mi) with purely inductive loads:

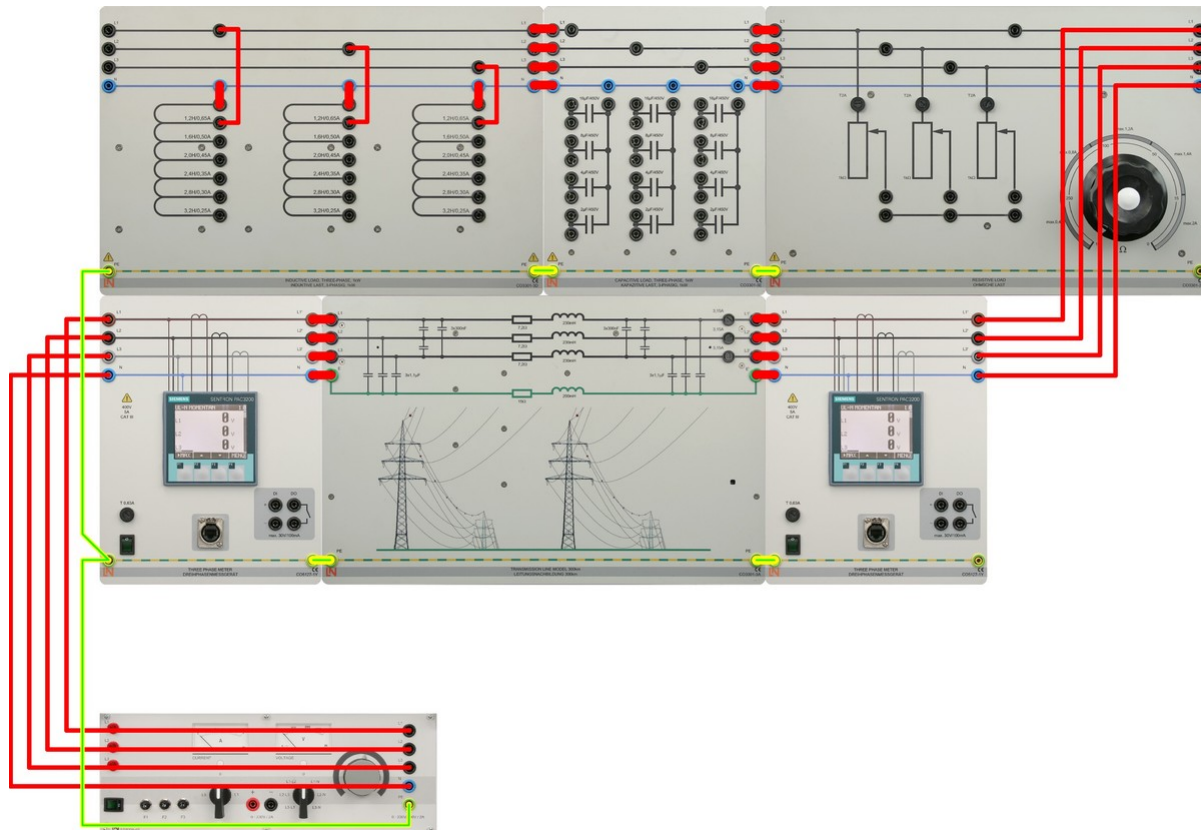

Figure 55:

Experiment circuit for measurements with purely inductive loads

1. Assemble the circuit as shown in Figure 55.
2. Connect inductors of 3.2 H in star configuration (Y).
3. Turn on the three-phase power source and set the voltage to the nominal value $V_{LL} = 380$ V at the beginning of the line and maintained at this value through readjustment wherever necessary.
4. Measure and record the variables indicated in Table 6. The powers (W, VAR, and VA) always accounts for three-phase values, i.e. total power levels.
5. Turn off the three-phase power supply.
6. Repeat steps 2 to 4 for inductor values of 2.8 H, 2.4 H, 2.0 H, 1.6 H, and 1.4 H. Readjusting the power supply to its nominal value wherever necessary.

150 km (93.22 mi)						
Ind	Line's Start			Line's End		
3 ϕ Y	I_{L1}	W	VAR	I_{L1}	V_{LL12}	VAR
3.2 H						
2.8 H						
2.4 H						
2.0 H						
1.6 H						
1.2 H						

Table 6:

Three-phase Power Transmission Line @ Inductive Load Configuration

Line length of 150 km (93.22 mi) with mixed resistive-inductive loads:

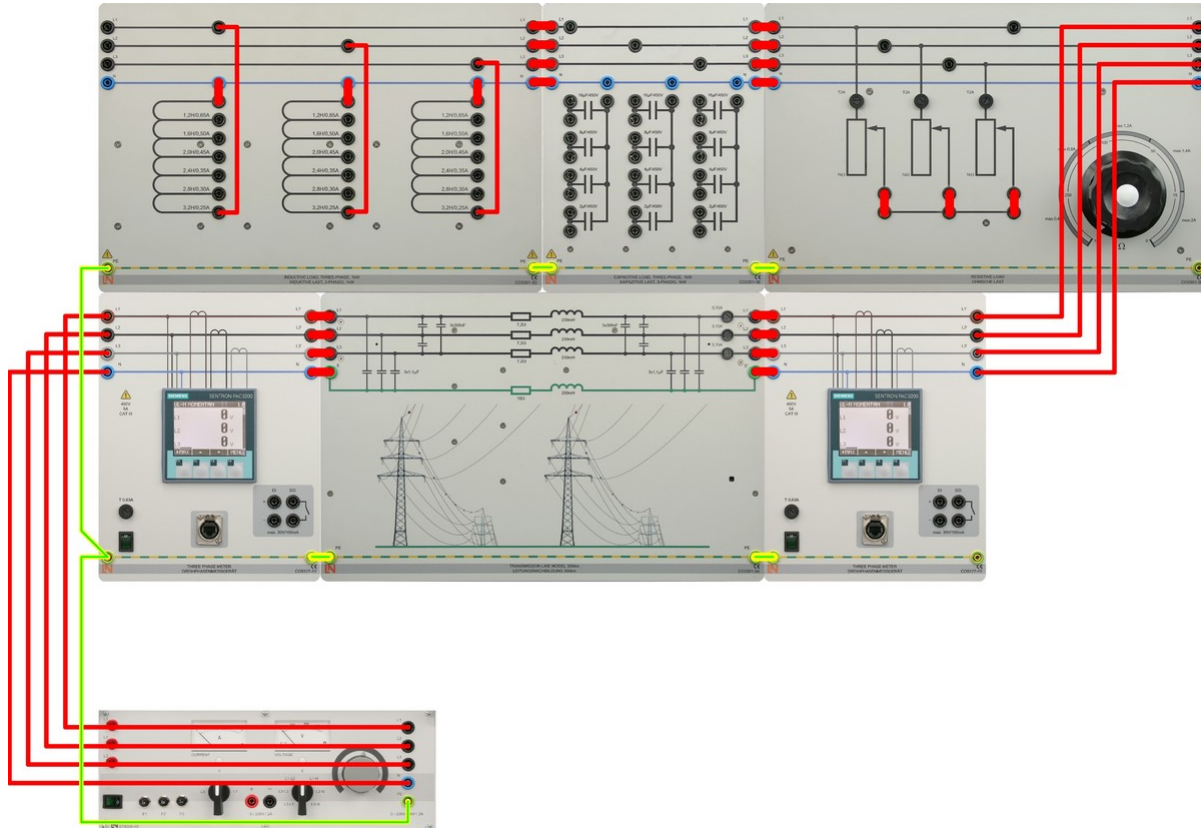

Figure 56:

Experiment circuit for measurements with mixed resistive-inductive loads

1. Assemble the circuit as shown in Figure 56.
2. Connect inductors of 3.2 H and resistor load in parallel and star configuration (Y) at the same time. Make sure the resistive load is at maximum value adjusting it by its knob.
3. Turn on the three-phase power source and set the voltage to the nominal value $V_{LL} = 380$ V at the beginning of the line and maintained at this value through readjustment wherever necessary.
4. Decrease the resistive load from its maximum value until you reach a total active power of 300 W measured at the end of the transmission line.
5. Measure and record the variables indicated in Table 7. The powers (W, VAR, and VA) always accounts for three-phase values, i.e. total power levels.
6. Turn off the three-phase power supply.
7. Repeat steps 2 to 5 for combination values of 2.0H // 400 W and 1.2 H // 500 W. Readjusting the power supply to its nominal value wherever necessary.

150 km (93.22 mi)								
Ind	W	Line's Start			Line's End			
$3\phi Y$	$3\phi Y$	I_{L1}	W	VAR	I_{L1}	V_{LL12}	VAR	$\cos \phi$
3.2 H	300 W							
2.0 H	400 W							
1.2 H	500 W							

Table 7:

Three-phase Power Transmission Line @ Mixed Resistive-Inductive Load Configuration

Line length of 150 km (93.22 mi) with reactive power compensation:

1. Assemble the circuit as shown in Figure 56.
2. Connect inductors of 1.2 H and resistor load in parallel and star configuration (Y) at the same time. Make sure the resistive load is at maximum value adjusting it by its knob.
3. Turn on the three-phase power source and set the voltage to the nominal value $V_{LL} = 380$ V at the beginning of the line and maintained at this value through readjustment wherever necessary.
4. Decrease the resistive load from its maximum value until you reach a total active power of 300 W measured at the end of the transmission line.
5. Measure and record the variables indicated in Table 8. The powers (W, VAR, and VA) always accounts for three-phase values, i.e. total power levels.
6. Connect capacitors of 4 μ F in star configuration (Y) in parallel with the RL load. Readjust the nominal voltage to 380 V and the resistive load to consume 300 W again.
7. Measure and record the variables indicated in Table 8.
8. Repeat steps 6 and 7 for capacitor values of 8 μ F.
9. Turn off the three-phase power supply.

150 km (93.22 mi)									
Ind	W	Cap	Line's Start			Line's End			
$3\phi Y$	$3\phi Y$	$3\phi Y$	I_{L1}	W	VAR	I_{L1}	V_{LL12}	VAR	$\cos \phi$
1.2H	300 W	0 μF							
1.2 H	300 W	4 μF							
1.2 H	300 W	8 μF							

Table 8:

Three-phase Power Transmission Line @ Reactive Power Compensation Configuration

Line length of 300 km (186.45 mi) with series compensation:

As described in the introduction, series compensation can be performed in the case of long transmission lines to avoid excessively high voltage drops along them. A series capacitor per transmission line can be used to reduce this drop. Three individual capacitances with the value $C = 1 / (\omega * X_L)$ are required for full compensation.

1. Assemble the circuit as shown in Figure 56. Make sure the transmission line of 300 km (186.45 mi) of length is used.
2. Connect inductors of 2.0 H and resistor load in parallel and star configuration (Y) at the same time. Assure the resistive load is at maximum value adjusting it by its knob.
3. Turn on the three-phase power source and set the voltage to the nominal value $V_{LL} = 400$ V at the beginning of the line and maintained at this value through readjustment wherever necessary.
4. Decrease the resistive load from its maximum value until you reach a total active power of 500 W measured at the end of the transmission line.
5. Measure and record the variables indicated in Table 9. The powers (W, VAR, and VA) always accounts for three-phase values, i.e. total power levels.
6. Turn off the three-phase power supply.
7. Calculate the series capacitor per line required for full compensation using the equation $C = 1 / (\omega * X_L)$. Record value in Table 9.
8. Connect the circuit of Figure 57 with the capacitor calculated in step 7 between the end of each outer conductor and the wattmeter. Keep inductors of 2.0 H in star configuration.
9. Turn on the power supply. Readjust the nominal voltage to 400 V at the start of the line and the resistive load to consume 500 W again.

10. Measure and record the variables indicated in Table 9.

-11. Turn Off the three-phase power supply.

300 km (186.45 mi)									
Ind	W	Cap	Line's Start			Line's End			
$3\phi Y$	$3\phi Y$	$3\phi Y$	I_{L1}	W	VAR	I_{L1}	V_{LL12}	VAR	$\text{Cos } \phi$
2.0 H	500 W	0 μF							
Series Cal C =									

Table 9:

Three-phase Power Transmission Line @ Series Compensation Configuration

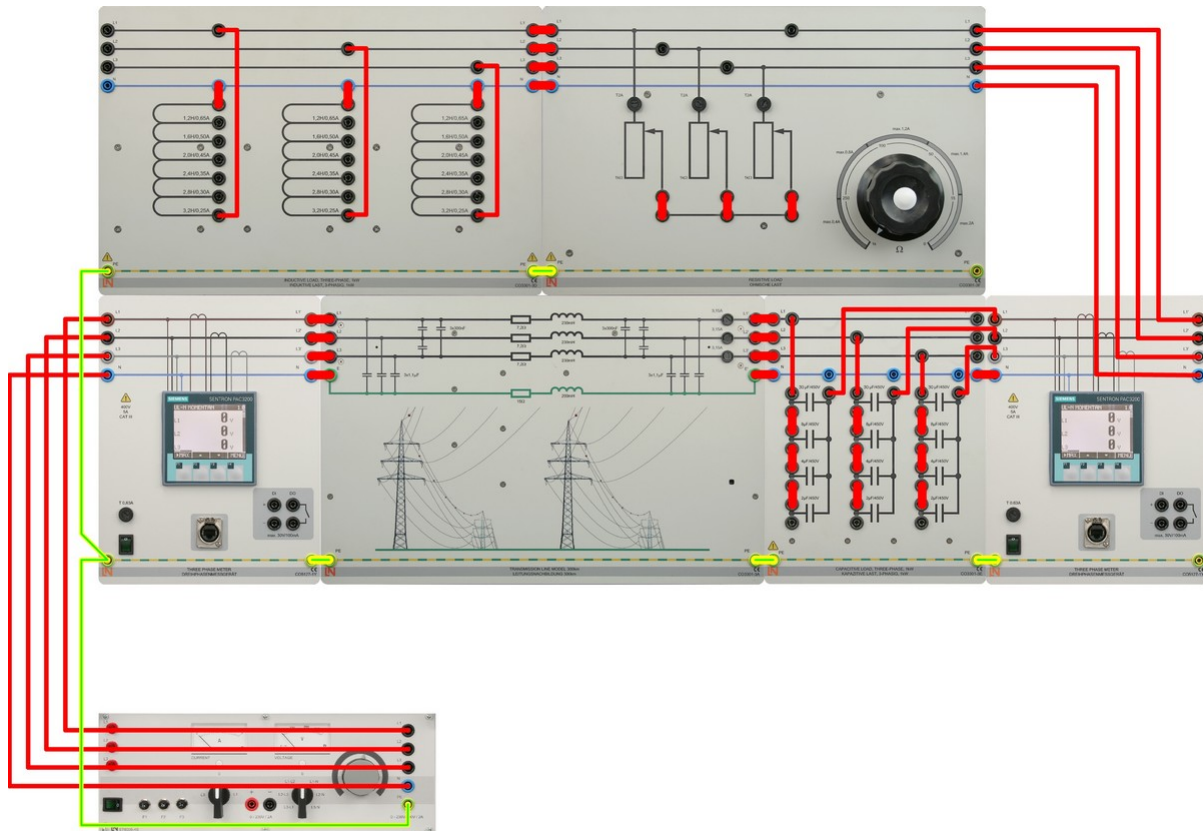

Figure 57:

Experiment circuit for measurements with series capacitor compensation

Report Questions

1. Plot active power (W) vs line's start and ends variables of Table 2 (resistive load configuration) for both transmission line lengths (93.22 and 186.45 mi).
 2. What can be said (explain) about the sign of the reactive power fed into the transmission lines under resistive load configuration?
 3. Calculate the load resistance (characteristic impedance) for both transmission lines using data of Table 3 and compare with their expected values for a lossless line.
 4. Determine the efficiency during matching for both transmission line lengths.
 5. Explain results of Table 4 for short circuit configuration from the standpoint of power transmission theory.
 6. Plot capacitor values (C) vs line's start and ends variables of Table 5 (capacitive load configuration) and explain the effect of capacitance at line's end. Why this occur?
 7. Plot inductor values (L) vs line's start and ends variables of Table 6 (inductive load configuration) and explain the effect of inductance at line's end. Why this occur?
 8. Plot inductor values (L) vs line's start and ends variables of Table 7 (mixed resistive-inductive load configuration) and explain any significant detail.
 9. What do the data of Table 8 (reactive power compensation) indicate from the point of view of power transmission theory?
 10. Explain the results of series compensation in a transmission line with an uncompensated state (Table 9).
-

Transmission Line with Earth Fault Compensation

Because of the high currents occurring in the event of a failure, the line model is operated at a rated voltage of 110 V during the experiments. At this rated voltage, too, the model realistically reproduces the values R , L and C_B . The measurements are carried out at a line length of 300 km (186.45 mi). Two three-phase wattmeters can be used to simultaneously measure all voltages and currents as well as active, reactive and apparent powers at both line's star and end of transmission lines. Increase the voltage of the feeding transformer at the start of the line in small increments to the specified value, making sure that the maximum permissible current (2.5 A) is not exceeded anywhere. All short-circuit tests should be carried out quickly and with efficiency at the specified supply voltage. The power supply should be switched off as soon as the desired readings have been obtained.

Procedure

Case 1: Measurement of Zero-sequence Impedance

The line's zero-sequence impedance must be known in order to analyze the line's response to asymmetric short circuits. The negative-sequence impedance does not need to be determined separately, since it's equal to the positive-sequence impedance in the case of static systems such as transmission lines.

Line length of 300 km (186.45 mi):

1. Assemble the circuit as shown in Figure 58. Make sure the transmission line of 300 km (186.45 mi) of length is used.
 2. Connect the three outer conductors to each other and to the neutral conductor at the end of transmission line.
 3. Turn on the three-phase power source and set the voltage to the nominal value $V_{LL} = 110$ V at the beginning of the line.
 4. Measure and record the variables indicated in Table 10. The powers (W, VAR, and VA) always accounts for three-phase values, i.e. total power levels.
 5. Turn off the three-phase power supply.
-

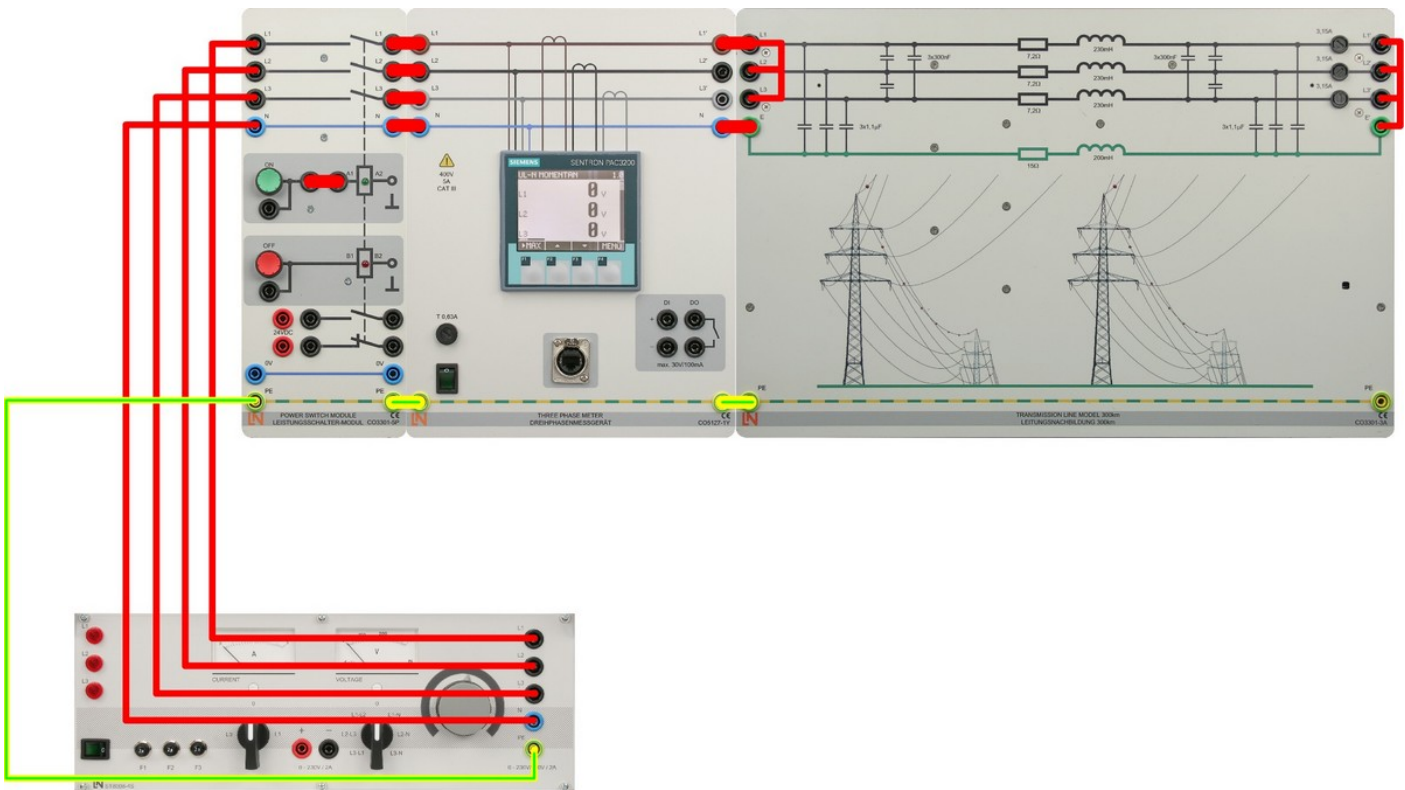

Figure 58:
Test Circuit for Determining Zero-sequence Impedance

300 km (186.45 mi)	
Line's Start	Line's Start
I_0 1 ϕ	Total W 3 ϕ

Table 10:
Measurement of Zero-sequence Impedance

Case 2: Symmetric (3-Pole) Short Circuit

Line length of 300 km (186.45 mi):

1. Assemble the circuit as shown in Figure 59.
2. Connect the three outer conductors to each other and to the neutral conductor N at the end of the second three phase watt-meter.
3. Turn on the three-phase power source and set the voltage to the nominal value $V_{LL} = 110$ V at the beginning of the line.
4. Measure and record the variables indicated in Table 11. The powers (W, VAR, and VA) always accounts for three-phase values, i.e. total power levels.
5. Turn off the three-phase power supply.

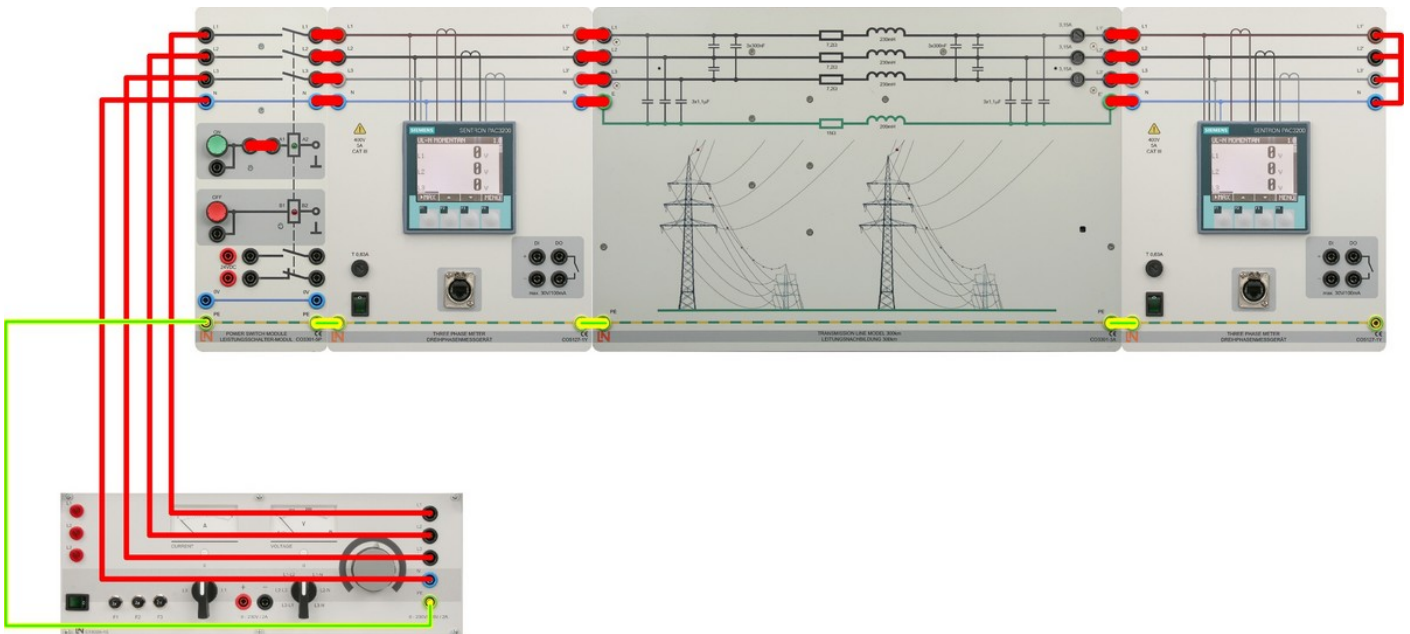

Figure 59:
Test circuit for measurements in the event of a 3-pole short circuit

300 km (186.45 mi)			
Line's Start			
V_{LL12}	I_{L1}	W	VAR

Table 11:
Measurement of 3-pole Short Circuit

Case 3: Single-pole Short Circuit (Earth Fault)

Line length of 300 km (186.45 mi):

1. Assemble the circuit as shown in Figure 60.
2. Connect the outer conductor L_1 to the neutral conductor N at the end of the second three phase watt-meter.
3. Turn on the three-phase power source and set the voltage to the nominal value $V_{LL} = 110$ V at the beginning of the line.
4. Measure and record the variables indicated in Table 12. The powers (W, VAR, and VA) always accounts for three-phase values, i.e. total power levels.
5. Turn off the three-phase power supply.

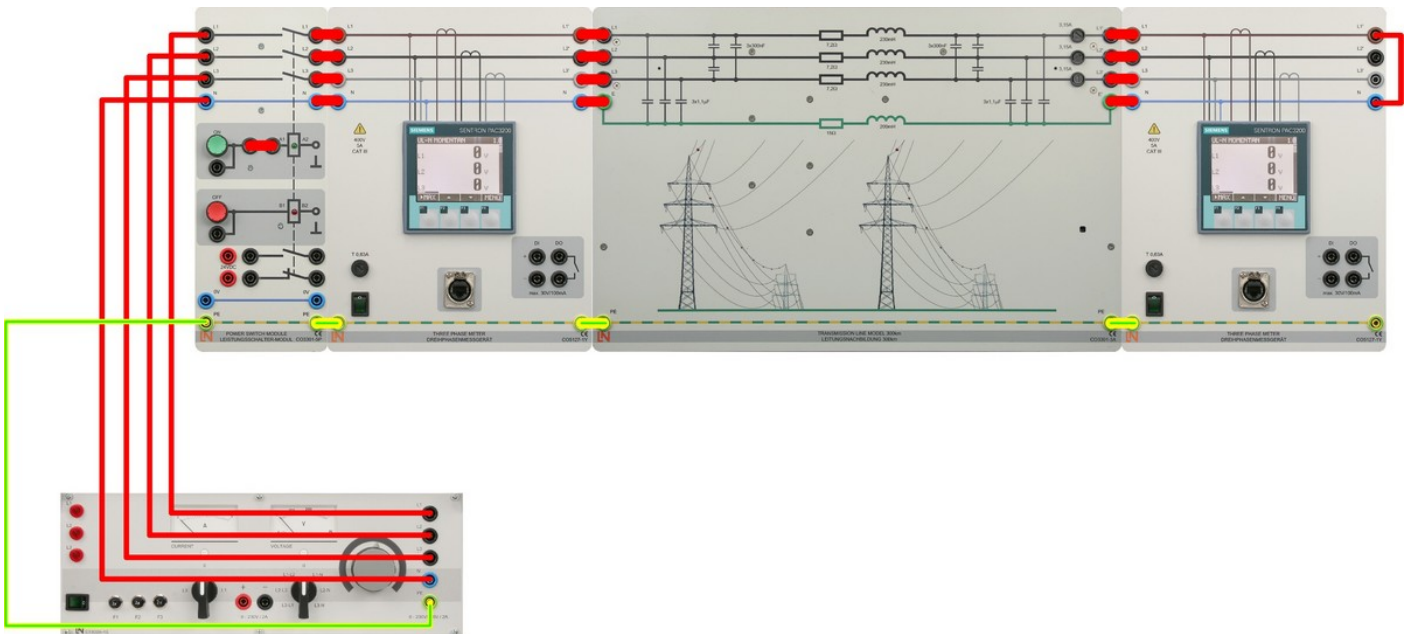

Figure 60:

Test circuit for measurements in the event of a single-pole short circuit

300 km (186.45 mi)			
Line's Start	Line's End		
V_{LL12}	I_{L1}	V_{LN2}	V_{LN3}

Table 12:

Measurements in the event of a single-pole short circuit

Case 4: Two-pole Short Circuit with Earth Fault

Line length of 300 km (186.45 mi):

1. Assemble the circuit as shown in Figure 61.
2. Connect the outer conductor L_2 and L_3 together and to the neutral conductor N at the end of the second three phase watt-meter. Use an additional ammeter to measure the sum $I_{SC\ 2-Pole}$ of the two currents if it's needed.
3. Turn on the three-phase power source and set the voltage to the nominal value $V_{LL} = 110\text{ V}$ at the beginning of the line.
4. Measure and record the variables indicated in Table 13. The powers (W , VAR , and VA) always accounts for three-phase values, i.e. total power levels.
5. Turn off the three-phase power supply.

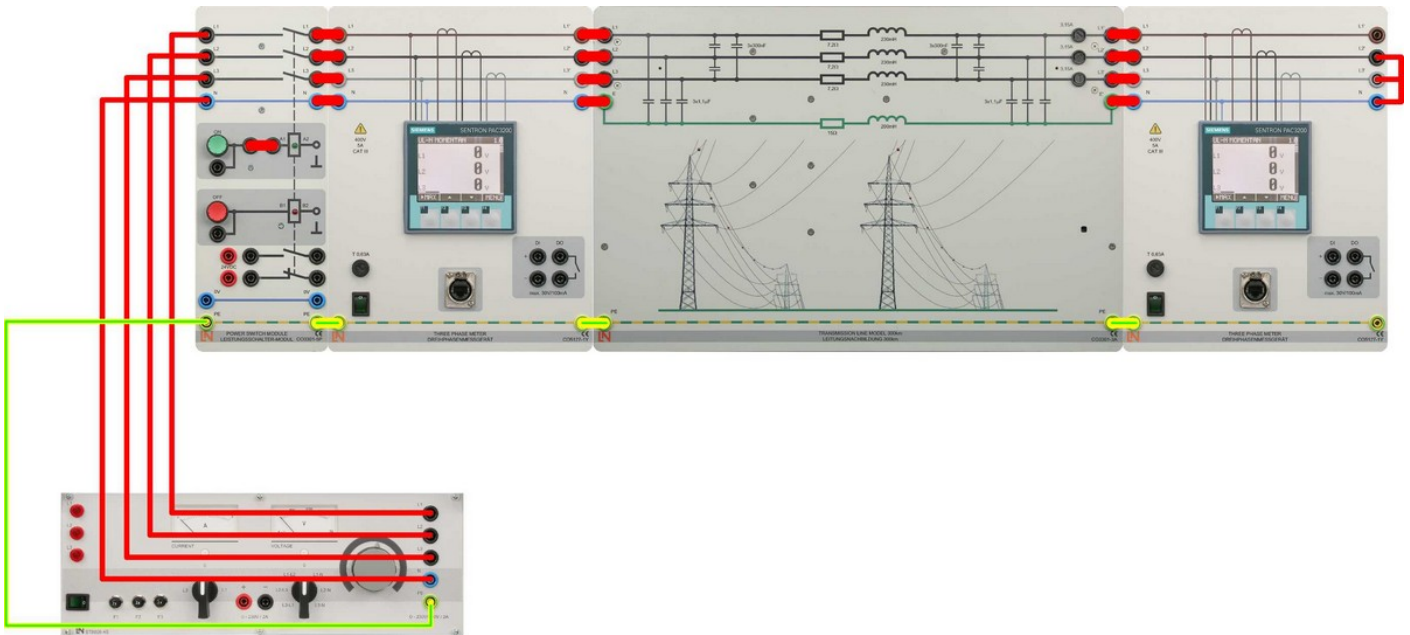

Figure 61:

Test circuit for measurement in the event of a 2-pole short circuit

300 km (186.45 mi)				
Line's Start	Line's End			
V_{LL12}	I_{L2}	I_{L3}	$I_{SC\ 2-POLE}$	V_{LN1}

Table 13:

Measurement in the event of a 2-pole Short Circuit with Earth

Case 5: Two-pole Short Circuit without Earth Fault

Line length of 300 km (186.45 mi):

1. Assemble the circuit as shown in Figure 61.
2. Connect the outer conductor L_2 and L_3 together and disconnect from neutral conductor N at the end of the second three phase watt-meter.
3. Turn on the three-phase power source and set the voltage to the nominal value $V_{LL} = 110$ V at the beginning of the line.
4. Measure and record the variables indicated in Table 14. The powers (W , VAR_2 and VA) always accounts for three-phase values, i.e. total power levels.
5. Turn off the three-phase power supply.

300 km (186.45 mi)			
Line's Start	Line's End		
V_{LL12}	$I_{L2} = I_{L3} = I_{SC\ 2-POLE}$	V_{LN1}	V_{LN23}

Table 14:

Measurement in the event of a 2-pole Short Circuit without Earth

Case 6: Earth Fault with Isolated Neutral Point

Line length of 300 km (186.45 mi):

1. Assemble the circuit as shown in Figure 62.
2. Connect the outer conductor L_1 to neutral conductor N at the end of the second three phase watt-meter. As shown, leave the neutral conductor N disconnected from the power supply.
3. Turn on the three-phase power source and set the voltage to the nominal value $V_{LL} = 110$ V at the end of the line.
4. Measure and record the variables indicated in Table 15. The powers (W, VAR, and VA) always accounts for three-phase values, i.e. total power levels.
5. Turn off the three-phase power supply.

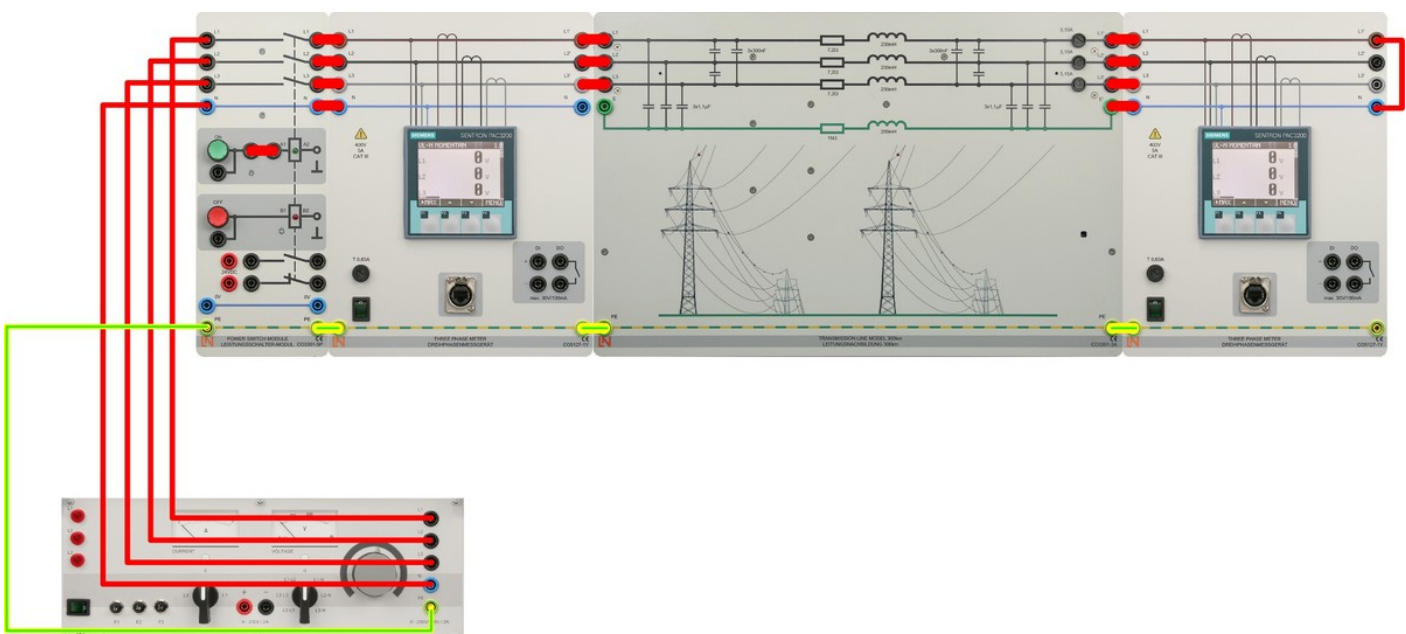

Figure 62:

Test circuit for measurements in the event of an earth fault

300 km (186.45 mi)		
Line's End		
V_{LL12}	I_{L1}	V_{LN23}

Table 15:
Measurements in the event of an earth fault

Case 7: Earth Fault Compensation

Line length of 300 km (186.45 mi):

1. Assemble the circuit as shown in Figure 63.
2. Connect the outer conductor L_1 to neutral conductor N at the end of the second three phase watt-meter. As shown, connect the earth-fault quenching coil into the neutral conductor N between the power supply and line model.
3. Turn on the three-phase power source and set the voltage to the nominal value $V_{LL} = 110$ V at the end of the line.
4. Successively set the inductance values to 1.0 H on the coil.
5. Measure and record the variables indicated in Table 16. The powers (W, VAR, and VA) always accounts for three-phase values, i.e. total power levels.
6. Repeat steps 4 and 5 for any inductance values between 1.2 H and 2.0 H on the coil.
7. Turn off the three-phase power supply.

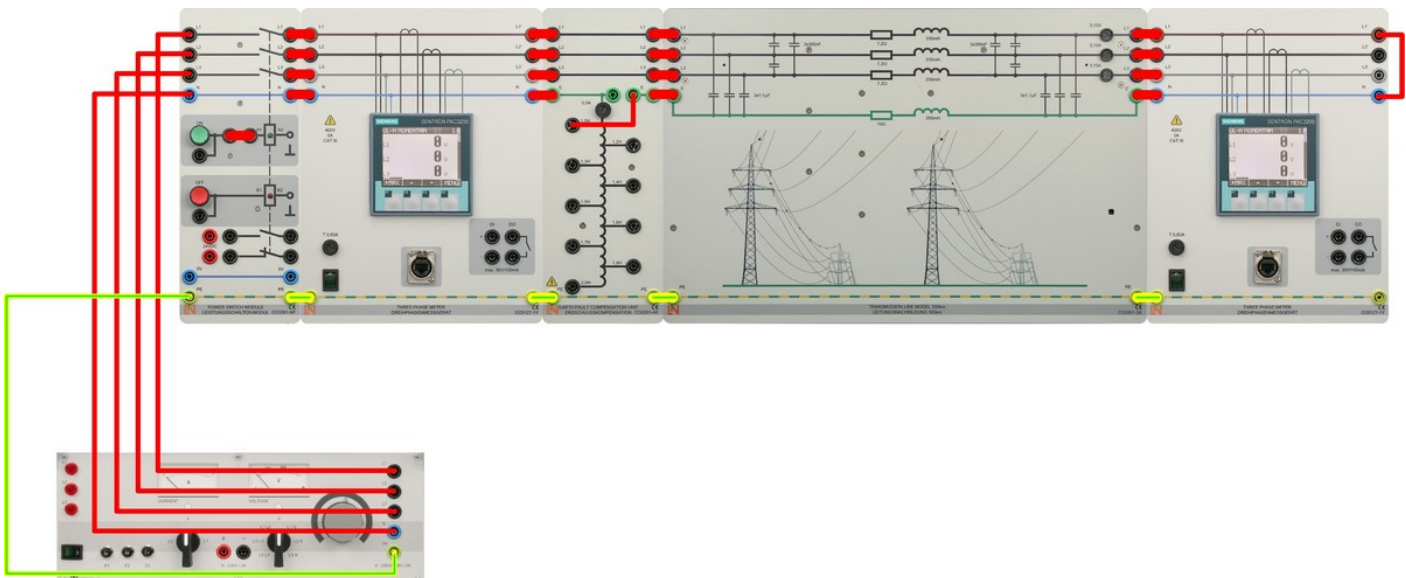

Figure 63:
Test circuit for measurements with an earth-fault quenching coil

300 km (186.45 mi)									
Line's	Quenching Coil Inductance (H)								
End	1	1.2	1.3	1.4	1.5	1.6	1.7	1.8	2
I_{L1}									
V_{LN23}									

Table 16:
Measurements with an earth-fault quenching coil

Report Questions

1. Determine zero-sequence impedance $Z_0 = (R_0 + jX_0)$ using data of Table 10 and compare with theoretical calculated value from introduction.
2. What reveals the power measurements from Table 11 (symmetric short circuit) and explain why.
3. What happens when the connection to the neutral conductor N is removed in the symmetric short circuit configuration.
4. Compare measured results of Table 11 with calculated values for 3-pole short circuit (Case 2).
5. Compare measured data of Table 12 with calculated values of single pole short circuit. Use the method of symmetric components if needed it. (Case 3).
6. Compare calculated values of two-pole short circuit with earth fault with measured data from Table 13. Use the method of symmetric components if needed it. (Case 4).
7. Compare calculated values of two-pole short circuit without earth fault with measured data from Table 14. Use the method of symmetric components if needed it. (Case 5).
8. At which inductance is the fault current minimized for earth fault compensation? What are the related values of the voltages for the intact outer conductors? (Case 7).
9. Calculate the earth-fault quenching coil's inductance during resonance of the transmission line used in the experiment.

Voltage Regulation with a Three-phase Variable Transformer

The experiments here examine the behavior of a three-phase variable transformer configured as autotransformer, in conjunction with a line model and connected load. First, the voltage ranges covered by the transformer at the different control settings are determined. Also investigated in this process is the autotransformer's short-circuit behavior. After that, a combination of a transformer and line model is set up, and the transformer's tap changers set manually in accordance with various load situations. Also performed later is automatic voltage adjustment which ensures a constant voltage at the consumer node, regardless of the load current.

Procedure

Case 1: Three-phase Variable Transformer Under Short Circuit Mode

Autotransformers have very low short-circuit voltages. Measuring such voltages is useful only if the transformation ratio is not equal to one, otherwise the primary side is short-circuited directly. The value of the rated power of transformers are calculated using $S = (\sqrt{3} * V_{LL}) * I_{LL}$.

1. Assemble the circuit as shown in Figure 64.
 2. Enter the rated values for the employed three-phase variable transformer CO3301-3P in Table 17.
 3. Determine the maximum transformation ratio under no-load and rated primary current. Record results in Table 17.
 4. Before begin measurements, you should set the transformer to the maximum voltage. Short-circuit the three phases on the its secondary side, and connect them to the neutral conductor.
 5. Turn on the three-phase power source and starting from a value of zero, *carefully* raise the power supply's three-phase voltage until the rated current flows on the transformer's primary side.
 6. Measure and record the variables indicated in Table 17. The powers (W, VAR, and VA) always accounts for three-phase values, i.e. total power levels.
 7. Turn off the three-phase power supply.
-

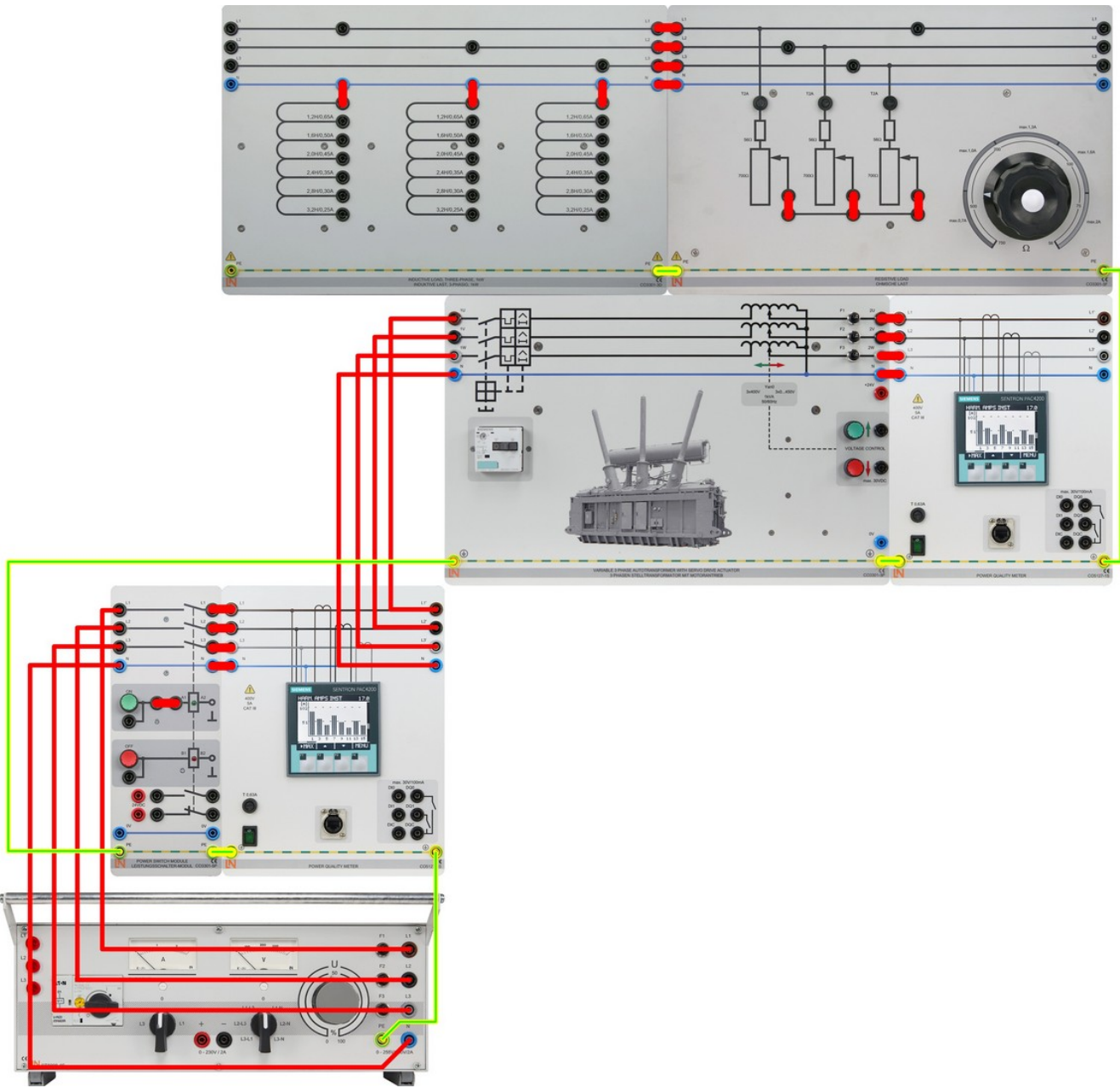

Figure 64:
Experimental configuration for no-load and short-circuit modes

Three-Phase Variable Transformer					
No Load	V_{LL12} Pri	Max V_{LL12} Sec	Min V_{LL12} Sec	Ratio	I_{pri} Rate
Short Circuit	V_{LL12} Pri	P (W) 3 ϕ	Q (Var) 3 ϕ	I_{L1}	

Table 17:
Measurements for No-load and Short-circuit Modes

Case 2: Line Model without Three-phase Variable Transformer

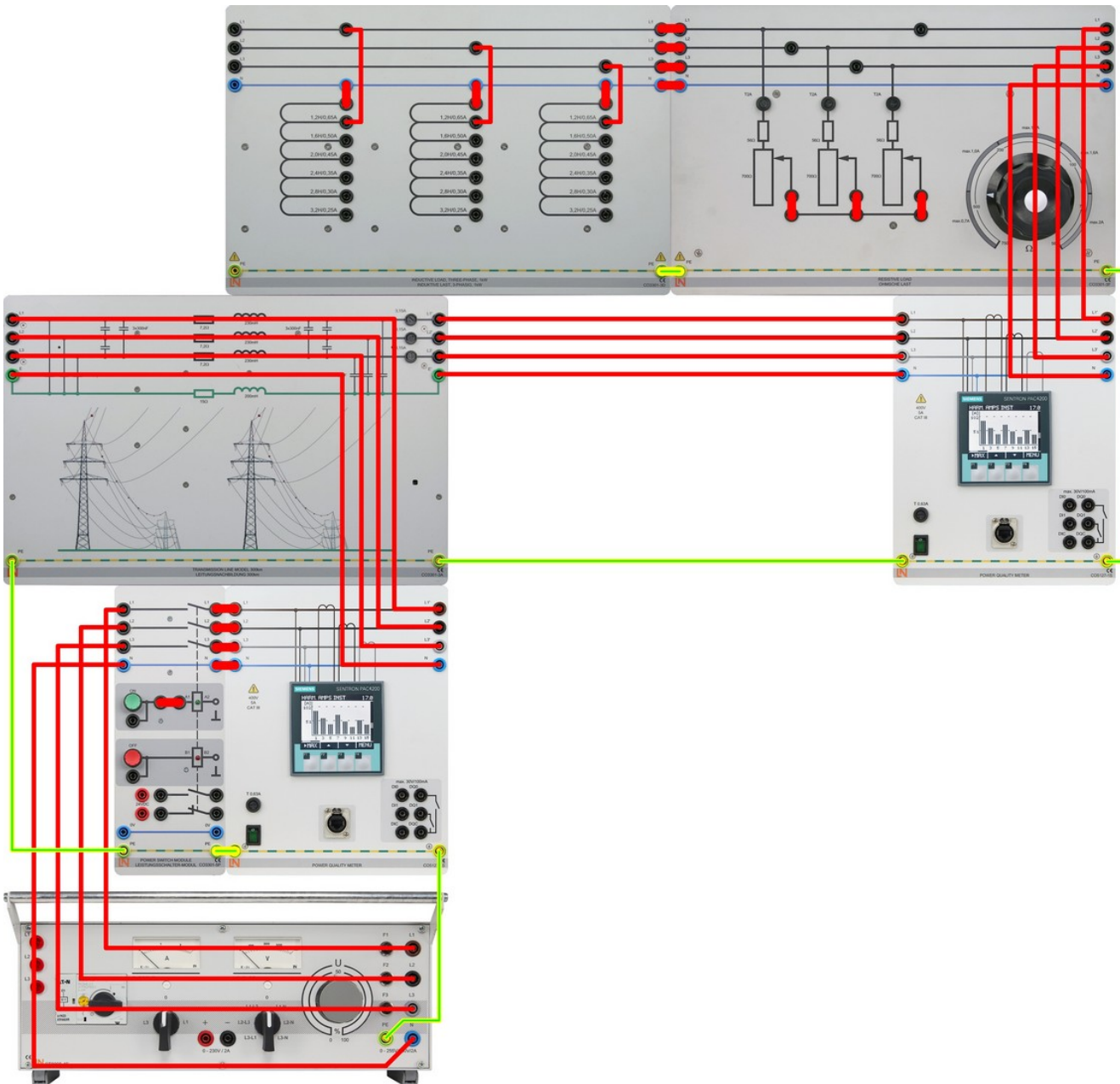

Figure 65:

Line model without a three-phase variable transformer

Line length of 150 km (93.22 mi) without three-phase variable transformer:

1. Assemble the circuit as shown in Figure 65.
2. Make sure the transmission line of 150 km (93.22 mi) of length is used and disconnect the inductive/resistive load from circuit.
3. Turn on the three-phase power source and set the voltage to the nominal value $V_{LL} = 380 \text{ V}$ at the start of the line.

4. Measure and record the variables indicated for no load in Table 18.
5. Turn off the three-phase power supply.
6. Connect the mixed resistive/inductive load to the line's end. Select a value of 1.2 H for L (in a star configuration). Due to the high current consumption, connect the resistive load in **delta** mode (Δ). Assure the resistive load is at maximum value adjusting it by its knob.
7. Turn on the three-phase power source and set the voltage to the nominal value $V_{LL} = 380$ V at the beginning of the line and maintained at this value through readjustment wherever necessary.
8. Decrease the resistive load from its maximum value until you reach a total active power of 600 W measured at the end of the transmission line.
9. Measure and record the variables indicated for load in Table 18.
10. Turn off the three-phase power supply.

Higher powers should not be selected, as this might overload the ohmic resistance.

Line length of 300 km (186.45 mi) without three-phase variable transformer:

1. Assemble the circuit as shown in Figure 65.
 2. Make sure the transmission line of 300 km (186.45 mi) of length is used and disconnect the inductive/resistive load from circuit.
 3. Turn on the three-phase power source and set the voltage to the nominal value $V_{LL} = 380$ V at the start of the line.
 4. Measure and record the variables indicated for no load in Table 18.
 5. Turn off the three-phase power supply.
 6. Connect the mixed resistive/inductive load to the line's end. Select a value of 2 H for L (in a star configuration). Connect the resistive load in delta mode (Δ). Assure the resistive load is at maximum value adjusting it by its knob.
 7. Turn on the three-phase power source and set the voltage to the nominal value $V_{LL} = 380$ V at the beginning of the line and maintained at this value through readjustment wherever necessary.
 8. Decrease the resistive load from its maximum value until you reach a total active power of 300 W measured at the load.
 9. Measure and record the variables indicated for load in Table 18.
 10. Turn off the three-phase power supply.
-

Line without Variable Transformer								
No	Line's Start				Line's End			
Load	V_{LL12}				V_{LL12}			
150 km (93.22 mi)								
300 km (186.45 mi)								
	Line's Start				Line's End			
Load	V_{LL12}	I_{L1}	P (W)	Q (Var)	V_{LL12}	I_{L1}	P (W)	Q (Var)
150 km (93.22 mi)								
300 km (186.45 mi)								

Table 18:
Measurements for Line without Variable Transformer

Case 3: Three-phase Variable Transformer at the End of the Line Model

Line length of 150 km (93.22 mi) with three-phase variable transformer at the end:

1. Assemble the circuit as shown in Figure 66.
2. Make sure the transmission line of 150 km (92.33 mi) of length is used and disconnect the inductive/resistive load from circuit.
3. Turn on the three-phase power source and set the voltage to the nominal value $V_{LL} = 380$ V at the start of the line. Perform a measurement under no-load to set the variable transformer initially to a ratio of 1.
4. Turn off the three-phase power supply.
5. Connect the mixed resistive/inductive load to the line's end. Select a value of 1.2 H for L (in a star configuration). Connect the resistive load in delta mode (Δ). Assure the resistive load is at maximum value adjusting it by its knob.
6. Turn on the three-phase power source and set the voltage to the nominal value $V_{LL} = 380$ V at the beginning of the line and maintained at this value through readjustment wherever necessary.
7. Decrease the resistive load from its maximum value until you reach a total active power of 600 W measured at the load.
8. Measure and record the variables in Table 19.
9. Turn off the three-phase power supply.
10. Change the value of L to 1.6 H in star configuration.

11. Turn on the three-phase power source and set the voltage to the nominal value $V_{LL} = 380$ V at the start of the line.
12. Now change the variable transformer's ratio such that the voltage across the load is 380 V. You will also need to readjust the ohmic resistance to maintain a constant load of 600 W.
13. Measure and record the variables indicated for load in Table 19.
14. Turn off the three-phase power supply.

Line length of 300 km (186.45 mi) with three-phase variable transformer at the end:

1. Assemble the circuit as shown in Figure 66.
 2. Make sure the transmission line of 300 km (186.45 mi) of length is used and disconnect the inductive/resistive load from circuit.
 3. Turn on the three-phase power source and set the voltage to the nominal value $V_{LL} = 380$ V at the start of the line. Perform a measurement under no-load to set the variable transformer initially to a ratio of 1.
 4. Turn off the three-phase power supply.
 5. Connect the mixed resistive/inductive load to the line's end. Select a value of 2.4 H for L (in a star configuration). Connect the resistive load in delta mode (Δ). Assure the resistive load is at maximum value adjusting it by its knob.
 6. Turn on the three-phase power source and set the voltage to the nominal value $V_{LL} = 380$ V at the beginning of the line and maintained at this value through readjustment wherever necessary.
 7. Decrease the resistive load from its maximum value until you reach a total active power of 300 W measured at the load.
 8. Measure and record the variables in Table 19.
 9. Now change the variable transformer's ratio such that the voltage across the load is 380 V. You will also need to readjust the ohmic resistance to maintain a constant load of 300 W.
 10. Measure and record the variables indicated for load in Table 19.
 11. Turn off the three-phase power supply.
-

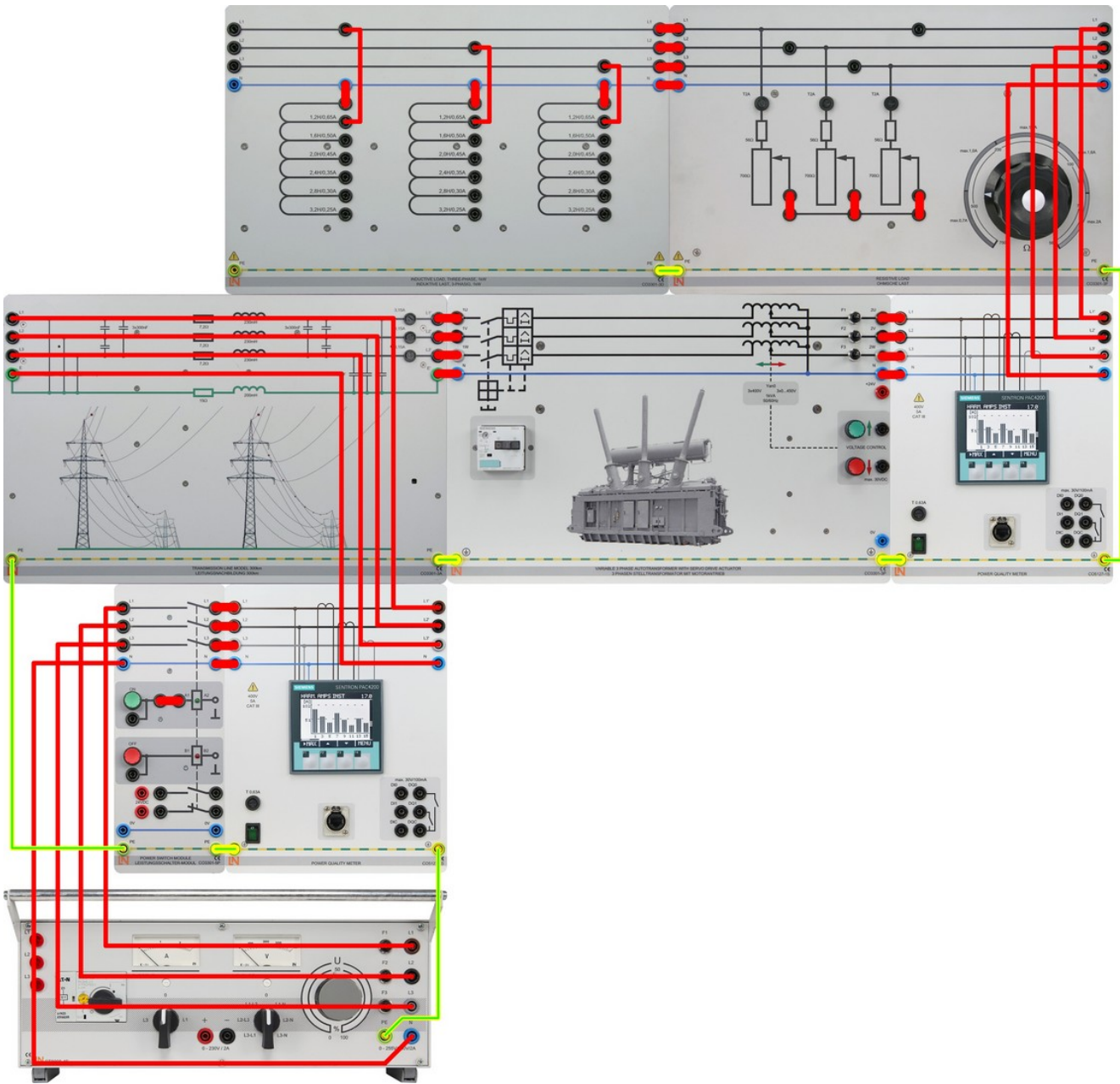

Figure 66:
Three-phase Variable Transformer at the End of the Line Model

Variable Transformer at the End of the Line Model								
Transformer	Line's Start				At the Load			
	V_{LL12}	I_{L1}	P (W)	Q (Var)	V_{LL12}	I_{L1}	P (W)	Q (Var)
Ratio = 1								
150 km (93.22 mi)								
300 km (186.45 mi)								
Transformer	Line's Start				At the Load			
	V_{LL12}	I_{L1}	P (W)	Q (Var)	V_{LL12}	I_{L1}	P (W)	Q (Var)
Ratio = Variable								
150 km (93.22 mi)								
300 km (186.45 mi)								

Table 19:
Measurements for Variable Transformer at the End of the Line Model

Case 3: Three-phase Variable Transformer at the Start of the Line Model

Line length of 150 km (93.22 mi) with three-phase variable transformer at the start:

1. Assemble the circuit as shown in Figure 67.
 2. Make sure the transmission line of 150 km (92.33 mi) of length is used and disconnect the inductive/resistive load from circuit.
 3. Turn on the three-phase power source and set the voltage to the nominal value $V_{LL} = 380$ V at the start of the line. Perform a measurement under no-load to set the variable transformer initially to a ratio of 1.
 4. Turn off the three-phase power supply.
 5. Connect the mixed resistive/inductive load to the line's end. Select a value of 1.2 H for L (in a star configuration). Connect the resistive load in delta mode (Δ). Assure the resistive load is at maximum value adjusting it by its knob.
 6. Turn on the three-phase power source and set the voltage to the nominal value $V_{LL} = 380$ V at the beginning of the line and maintained at this value through readjustment wherever necessary.
 7. Decrease the resistive load from its maximum value until you reach a total active power of 600 W measured at the load.
 8. Measure and record the variables in Table 20.
 9. Turn off the three-phase power supply.
 10. Change the value of L to 1.6 H in star configuration.
 11. Turn on the three-phase power source and set the voltage to the nominal value $V_{LL} = 380$ V at the start of the line.
 12. Now change the variable transformer's ratio such that the voltage across the load is 380 V. You will also need to readjust the ohmic resistance to maintain a constant load of 600 W.
 13. Measure and record the variables indicated for load in Table 20.
 14. Turn off the three-phase power supply.
-

Line length of 300 km (186.45 mi) with three-phase variable transformer at the start:

1. Assemble the circuit as shown in Figure 67.
2. Make sure the transmission line of 300 km (186.45 mi) of length is used and disconnect the inductive/resistive load from circuit.
3. Turn on the three-phase power source and set the voltage to the nominal value $V_{LL} = 380$ V at the start of the line. Perform a measurement under no-load to set the variable transformer initially to a ratio of 1.
4. Turn off the three-phase power supply.
5. Connect the mixed resistive/inductive load to the line's end. Select a value of 2.4 H for L (in a star configuration). Connect the resistive load in delta mode (Δ). Assure the resistive load is at maximum value adjusting it by its knob.
6. Turn on the three-phase power source and set the voltage to the nominal value $V_{LL} = 380$ V at the beginning of the line and maintained at this value through readjustment wherever necessary.
7. Decrease the resistive load from its maximum value until you reach a total active power of 300 W measured at the load.
8. Measure and record the variables in Table 20.
9. Now change the variable transformer's ratio such that the voltage across the load is 380 V. You will also need to readjust the ohmic resistance to maintain a constant load of 300 W.
10. Measure and record the variables indicated for load in Table 20.
11. Turn off the three-phase power supply.

Variable Transformer at the Start of the Line Model								
Transformer	Line's Start				At the Load			
Ratio = 1	V_{LL12}	I_{L1}	P (W)	Q (Var)	V_{LL12}	I_{L1}	P (W)	Q (Var)
150 km (93.22 mi)								
300 km (186.45 mi)								
Transformer	Line's Start				At the Load			
Ratio = Variable	V_{LL12}	I_{L1}	P (W)	Q (Var)	V_{LL12}	I_{L1}	P (W)	Q (Var)
150 km (93.22 mi)								
300 km (186.45 mi)								

Table 20:

Measurements for Variable Transformer at the Start of the Line Model

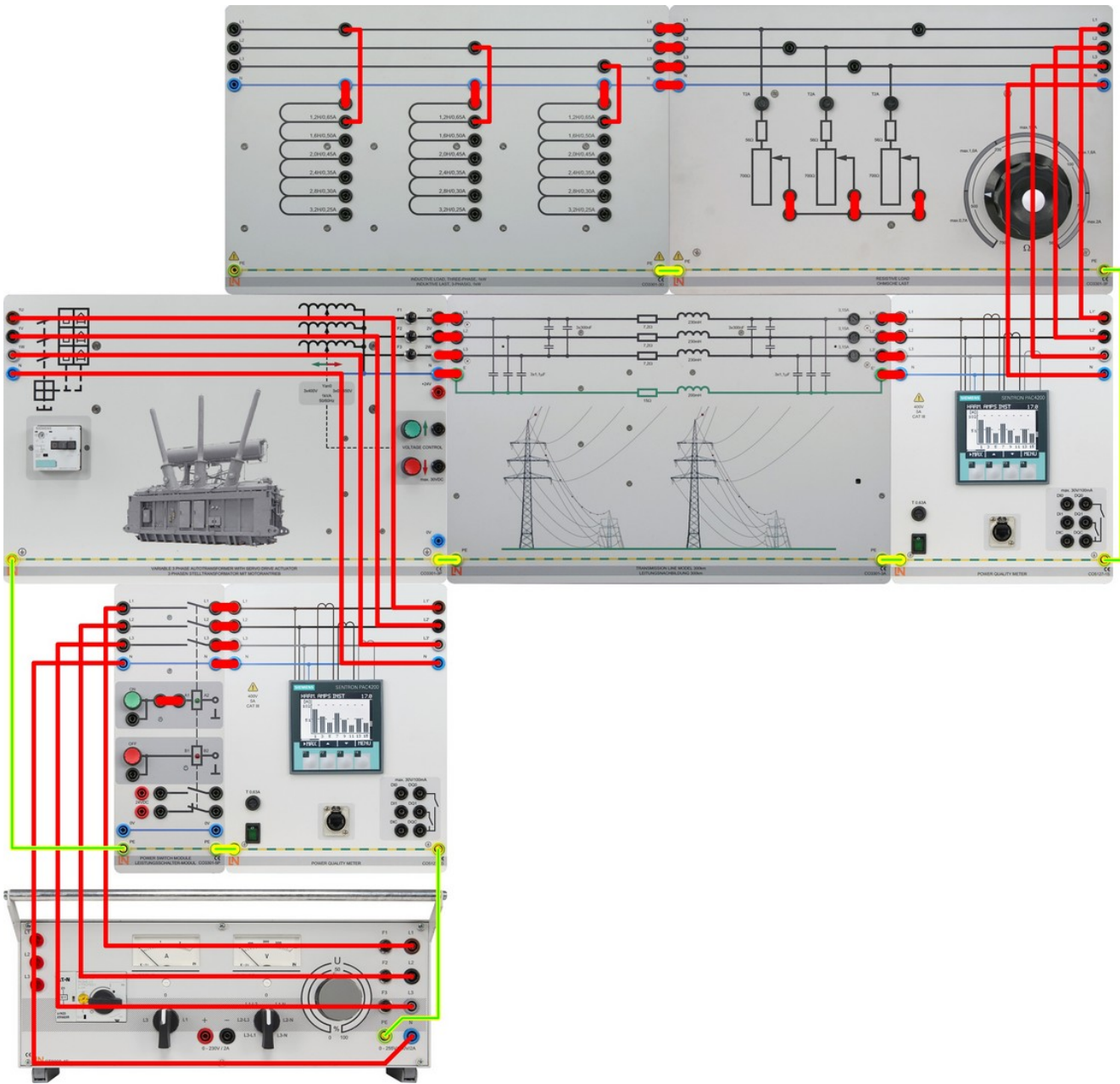

Figure 67:
 Three-phase Variable Transformer at the Beginning of the Line Model

Case 4: Automatic Voltage Regulation

Set up the circuit as illustrated next in Figure 68.

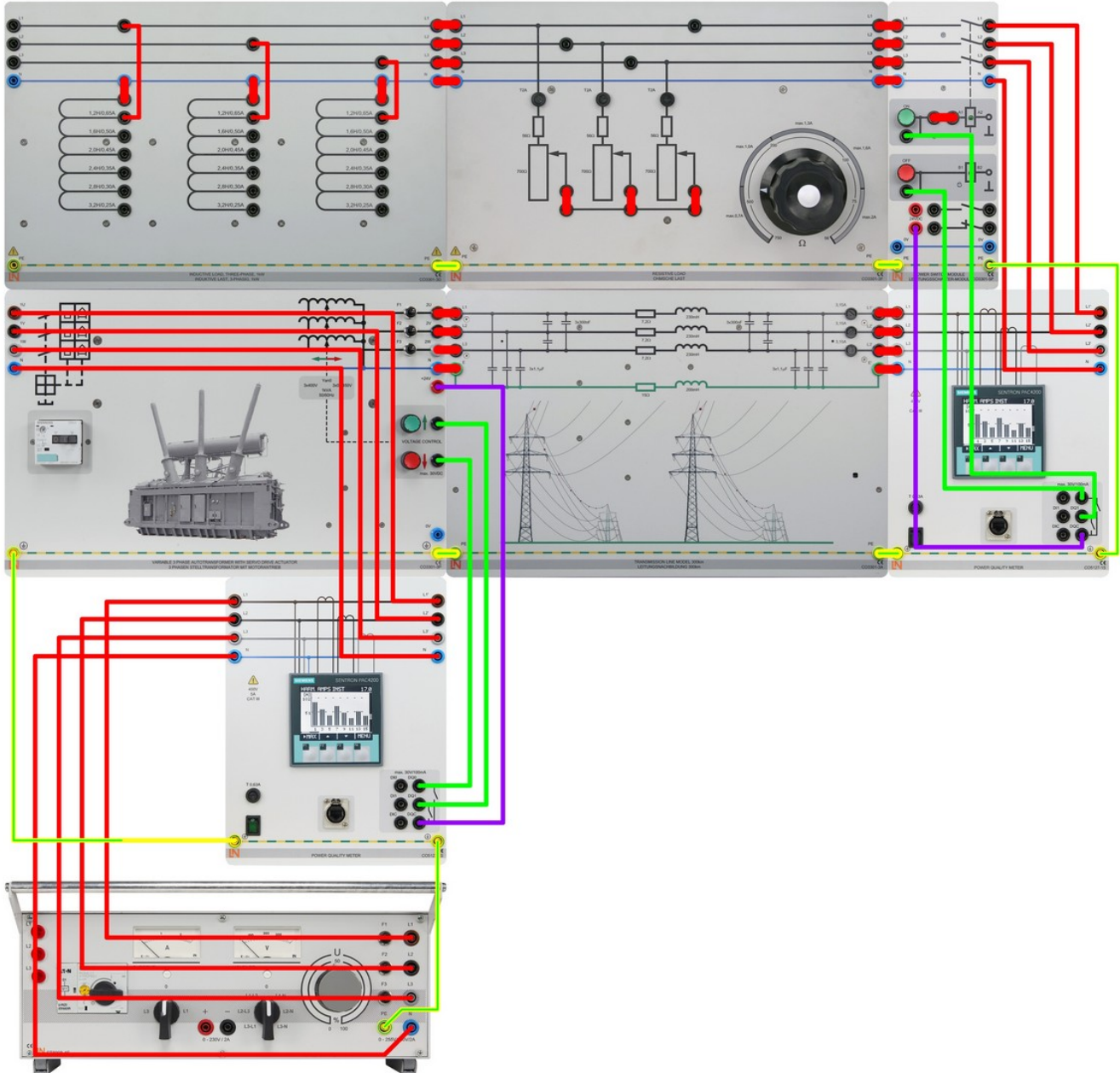

Figure 68:
Automatic voltage regulation (150 km/92.33mi)

Start the SCADA viewer and open the file for EUL8. On the viewer's start page, the file can be found under *energy transfer*; open the file named *EUL8.pvc* (usually in the templates subfolder *C:/Programs/LN/PowerLab/Templates*). The following overview of Figure 69 will appear:

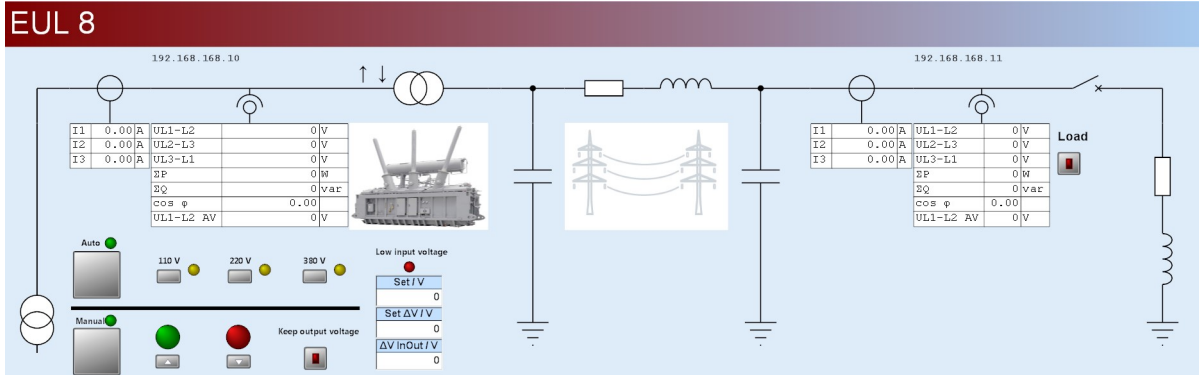



Figure 69:
EUL8 in SCADA

From left to right: Desktop transformer / laboratory power supply, measuring device 1 (before the transmission line), variable transformer, transmission line, measuring device 2 (behind the transmission line), power switch (with underlying control module), RL load.

It is assumed that you have programmed SCADA and the involved multimeters for mutual communication. If not, you should perform the necessary settings as described in the chapter on "[Configuring SCADA for PowerLab](#)".

Start SCADA via the diagnostic option ().

Do not pause or stop SCADA () while the variable transformer is regulating. To stop an experiment, activate the manual mode and then stop SCADA and, consequently, the PLC; this ensures that control requests for the transformer do not linger despite PLC deactivation.

1. Setting the Supply Voltages:

1. Conduct all the experiment with a transmission line length of **150 km (93.22 mi)**. Set the inductive load to **1.2 H in star configuration** and the resistive load to its maximum value by its knob.
2. Activate the load in SCADA via power switch **CO3301-5P**.
3. Turn on the three-phase power source **CO3301-3Z** and set the voltage to the nominal value $V_{LL} = 380 \text{ V}$ at the start of variable transformer **CO3301-3P**.
4. Adjust **variable transformer CO3301-3P** to a $V_{LL} = 220 \text{ V}$ in manual button mode via the SCADA software.

7. Decrease the **resistive load** from its maximum value until you reach a total active power of **300 W** measured at the load's three-phase power meter.
8. Set the **resistive load** such that a reading of **400 W** is obtained on the load measuring device. Variable transformer CO3301-3P needs to be readjusted to 220 V in this process.
9. Deactivate load power switch CO3301-5P again.
- : . Adjust **variable transformer CO3301-3P back to a $V_{LL} = 220$ V** in manual button mode via the SCADA software.

2.Manual Voltage Regulation:

1. Operate the SCADA control system in the manual mode (manual LED shines, *Keep output voltage* is inactive).
 2. Set the measurement in the logger for an appropriate time period and scale the chart axes to fit the measured values(to configure: right-click on the diagram, select properties).
 3. Start recording in the logger.
 4. Activate the load in SCADA via power switch **CO3301-5P**.
 5. Stop recording in the logger. Save the plot as image file for your report.
 6. Start recording in the logger again.
 7. Adjust the load resistance so that 400 W of active power are produced again. Though it might not be possible to achieve 400 W, this would not significantly influence the experiment.
 8. Stop recording in the logger. Also, save the plot for your report.
 9. Turn off the three-phase power supply.
 10. Set the supply voltages and resistive load again as described in section 1 "Setting the Supply Voltages".
 11. Operate the SCADA control system in the manual mode (manual LED shines, *Keep output voltage* is inactive).
 12. Start recording in the logger.
 13. Activate the load in SCADA via power switch **CO3301-5P**.
 14. Increment the variable transformer voltage to $V_{LL} = 220$ V so as to achieve an active power of 400 W again.
 15. Stop recording in the logger. Save the plot as image file for your report.
-

3. Automatic Voltage Regulation:

1. Set the supply voltages and resistive load again as described in "Setting the supply voltages".
2. Operate the SCADA control in the automatic mode for the variable transformer at a line-to-line voltage of 220 V ($V_{LL} = 220V$).
3. Start recording in the logger.
4. Activate the load in SCADA via power switch CO3301-5P.
5. Stop recording in the logger once the electrical values have stabilized. Save the plot as image file for your report.

Report Questions

1. From the data of Table 17, determine the values of the short-circuit resistance R_{SC} , short-circuit reactance X_{SC} , short-circuit impedance Z_{SC} and relative short-circuit voltage V_{SC} .
 2. In which percentage range does the voltage at the line's end lie, with respect to the value at the line's start in case 2 (No variable Transformer)?
 3. In which percentage range do the transmission losses lie, with respect to the active load in case 2 (No Variable Transformer)?
 4. Using results of Table 18, explain the effect of load and no-load in a power transmission system without variable transformer (Case 2).
 5. Which arrangement of line and variable transformer is more convenient in terms of transmission losses? Why?
 6. Plot the curves of step 5 from manual voltage regulation (load activation). What can be observed once the load has been activated?
 7. Plot the curves of step 8 from manual voltage regulation (resistance adjustment). What happens if you try to adjust the resistance to obtain the previously set active power of 400 W without changing the voltage again?
 8. Plot the curves of step 15 from manual voltage regulation (voltage adjustment). What happens if you try to raise the voltage in order to achieve the active power of 400 W at the load?
 9. Plot the curves of step 5 from automatic voltage regulation.
 10. Which method of active power adjustment is more practical for nationwide transmission of electricity?
-

References

Prof. G. Schultz, *Power Transmission*, Lucas-Nülle GmbH, 2018.
